

hotrod[®]
Cartridge Heaters



hotrod[®]

Cartridge Heaters

Components

We provide our customers with an extensive portfolio of technically mature products from the field of heating elements, thermal sensors and control technology. Since 1973, we have manufactured heating elements in Germany, and since 2002, we have been continuously developing our production location in Malta.

The manufactured products are usually individually-tailored to the customer – in extremely small unit numbers or in large quantities, at an attractive price. Our core process is organized highly efficiently using our own software, and we provide customer storage in all significant global markets. We work with our own specialists in order to select the best product for our customers.

Facts

- For heating applications:
 - Packaging machines
 - Extruders
 - Casting machines
 - Hot melt
 - Cutting knives
 - Analytical equipment in laboratories
- Custom options:
 - Power distribution
 - Numerous attachments and protection sleeves
 - Various moisture protection options
- Special Features:
 - High quality stainless steel with special alloy properties for improved heat conductivity, thermal expansion and corrosion resistance
 - Standard diameter tolerances to fit H7 bore tolerances
 - The most precise diameter tolerances in the industry: up to -0.02 -0.04 mm available
 - Various VDE certified versions
 - Certified according to UL and CSA standards on request
 - Protection class IP67 available on request

Application Fields

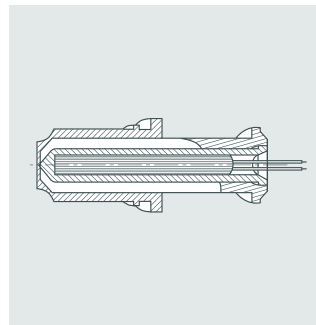

Plastic injection molding
Internal heating of nozzles

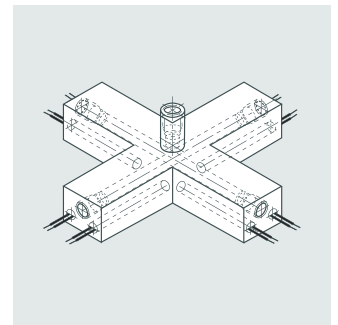

Hot runner systems
Heating of manifolds

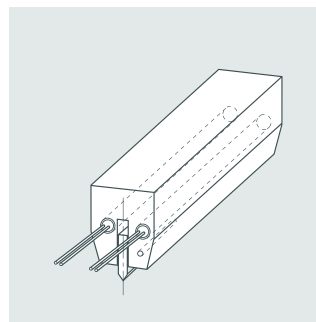

Packaging industry
Heating of sealing bars

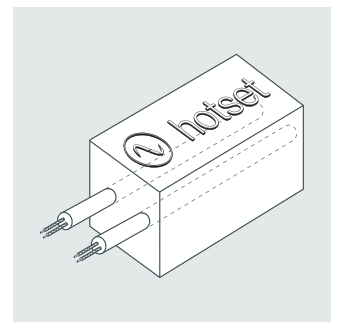

Packaging industry
Heating of hot stamps

Technical Key Features

Sheath material	Stainless steel 1.4541
Heating conductor material	NiCr 8020
Max. sheath temperature	750 °C / 1380 °F (up to 1000 °C / 1832 °F on request)
Max. voltage	480 V, UL rated: 250 V
Wattage tolerance*	± 10 %
Dielectric strength*	1500 V AC for > 24 V operation voltage 500 V for ≤ 24 V operation voltage
Insulation resistance*	≥ 5 MΩ at 500 V DC
Leakage current*	≤ 0.5 mA at 253 V AC
Length tolerance	± 1.5 %, min ± 1 mm
Standard diameter tolerance for metric sizes:	-0.02 -0.06 mm
Standard diameter tolerance for imperial sizes:	± 0.79 mil [± 0.02 mm]

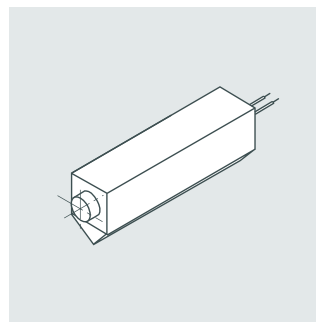

Textile industry
Heating of cutting knives

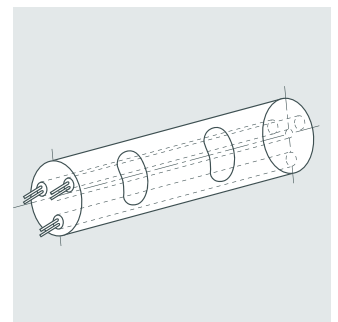

Paper industry
Heating of embossing rollers

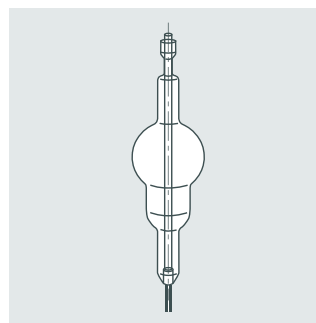

Laboratories
Heating of analytical equipment,
for example, mass spectrometer

*tested at environmental temperature



Performance Range

Options

Type	Ø	Ø-Tolerance	max. L [mm/inch]	max. W/cm ²	max. W/inch ²	max. W/cm ² UL rated	max. Temp [°C/°F]	max. U [V]	Thermocouple	Attachments	Power Distribution	Moisture Protection	Express																																																			
HHP	4 mm	-0.02 mm -0.06 mm	350 / 13.8	20	129	n/a	275/650 527/1202	250	limited	no	yes	limited	no																																																			
	6.0 mm	-0.02 mm -0.06 mm	1500 / 59	65*	419*	57*	750/ 1380	480	yes	yes		limited	IP67	24 h																																																		
		± 0.1 mm	3000 / 118	10	65	10						limited																																																				
	6.5 mm	-0.02 mm -0.06 mm	1500 / 59	65*	419*	57*						750/ 1380			480	yes	yes	IP67	24 h																																													
		± 0.1 mm	3000 / 118	10	65	10														limited																																												
	8 mm	-0.02 mm -0.06 mm	1500 / 59	65*	419*	57*														750/ 1380	480	yes	yes	IP67	24 h																																							
		± 0.1 mm	3000 / 118	10	65	10																				limited																																						
	10 mm	-0.02 mm -0.06 mm	1500 / 59	65*	419*	57*																				750/ 1380	480	yes	yes	IP67	24 h																																	
		± 0.1 mm	3000 / 118	10	65	10																										limited																																
	12.5 mm	-0.02 mm -0.06 mm	1500 / 59	65*	419*	57*																										750/ 1380	480	yes	yes	IP67	24 h																											
		± 0.1 mm	3000 / 118	10	65	10																																limited																										
	16 mm	-0.02 mm -0.06 mm	1500 / 59	65*	419*	57*																																750/ 1380	480	yes	yes	IP67	24 h																					
		± 0.1 mm	3000 / 118	10	65	10																																						limited																				
	20 mm	-0.02 mm -0.06 mm	1500 / 59	65*	419*	57*																																						750/ 1380	480	yes	yes	IP67	24 h															
		± 0.1 mm	3000 / 118	10	65	10																																												limited														
	1/8"	± 1.97 mil	150	20																																														700	250	no	no	yes	IP67	24 h								
	1/4"	± 0.79 mil	1500 / 59	65*	419*	57*																																												750/ 1380	480	yes	yes				IP67	24 h						
		± 3.94 mil	3000 / 118	10	65	10																																																					limited					
	3/8"	± 0.79 mil	1500 / 59	65*	419*	57*																																																					750/ 1380	480	yes	yes	IP67	24 h
		± 3.94 mil	3000 / 118	10	65	10																																																										
1/2"	± 0.79 mil	1500 / 59	65*	419*	57*	750/ 1380					480																																																					
	± 3.94 mil	3000 / 118	10	65	10		limited																																																									
5/8"	± 0.79 mil	1500 / 59	65*	419*	57*		750/ 1380	480	yes	yes			IP67	24 h																																																		
	± 3.94 mil	3000 / 118	10	65	10							limited																																																				
3/4"	± 0.79 mil	1500	65*	419*	57*							750/ 1380			480	yes	yes	IP67	24 h																																													
	± 0.394 mil	3000	10	65	10															limited																																												
LHT	6.5 mm	± 0.1 mm	3000 / 118	10	65															10	750/ 1380	480	no	limited	no																																							
	8 mm	± 0.1 mm	3000 / 118																																																													
	10 mm	± 0.1 mm	3000 / 118																																																													
	12.5 mm	± 0.1 mm	3000 / 118																																																													
	16 mm	± 0.1 mm	3000 / 118																																																													
	20 mm	± 0.1 mm	3000 / 118																																																													
LHT bendable	6.5 mm	± 0.2 mm	3000 / 118	700/ 1292																																																												
LHT bendable	8 mm	± 0.2 mm	3000 / 118																																																													

Formula for calculating the surface load: $W/cm^2 = \frac{\text{Wattage [W]}}{\text{Circumference [cm]} \times \text{heated length [cm]}}$

*Surface load > 10 W/cm² we recommend a H7 tolerance bore. • Surface load > 20 W/cm² we recommend a press fit. • Maximum surface load depends on heater sheath temperature.

hotrod® HHP/G

Casting Cartridge Heater

- Optimal temperature of the material in the goose neck
- Removal stud
- With angle block, tube section and metal sleeving

Specifications	
Sheath material	Stainless steel 1.4541
Heating conductor material	NiCr 8020
Diameter mm	6.5 / 8.0 / 10.0 / 12.5 / 16.0 / 20.0
Max. length	On request
Max. sheath temperature	750 °C / 1380 °F
Max. voltage	480 V, UL rated: 250 V
Wattage tolerance*	± 10 %
High voltage test*	1500 V AC for > 24 V operation voltage, 500 V for ≤ 24 V operation voltage
Insulation resistance*	≥ 5 MΩ at 500 V DC
Leakage current*	≤ 0.5 mA at 253 V AC
Length tolerance	± 1.5 %, min ± 1 mm
Standard diameter	metric: -0.02 -0.06 mm imperial: ± 0.79 mil [± 0.02 mm]

*tested at environmental temperature

Options

- Wattage distribution
- Thermocouple type K
- Various connection options

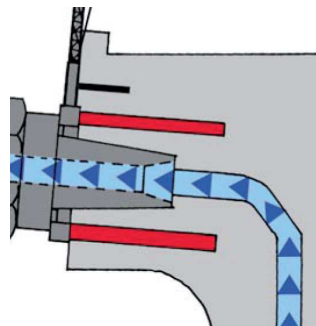

Heating of the goose neck

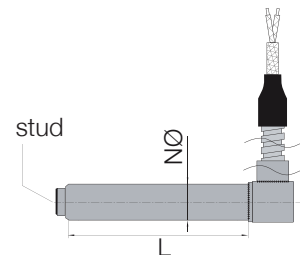

NØ = Nominal diameter · L = Length

Stock Range HHP/G

Connection Voltage: 230V, GLS Lead, 1500 mm

Stock ID	Diameter [mm]	Length [mm]	Connection length [mm]	Wattage [W]	Voltage [V]	Goose neck / Nozzle type
HT9906100	10.0	80	1500	250	230	Nozzle DAW 5
HT9906101	12.5	60	1500	200	230	DAW 5
HT9906104	12.5	90	1500	350	230	Nozzle DAW 20
HT9906103	16.0	80	1500	315	230	DAW 10/20
HT9906106	16.0	100	1500	500	230	DAW 40-125
HT9906113	16.0	100	1500	600	230	DAW 40-125
HT9906105	16.0	160	1500	630	230	Nozzle DAW 40-50
HT9906110	20.0	100	1500	630	230	DAW 160-200

hotrod® HHP Ø 4 mm High Power Cartridge Heater

Specifications	
Max. sheath temperature	275/650 °C // 527/1202 °F
Max. sheath surface load	20 W/cm ² / 129 W/inch ²
Max. Length	350 mm / 13.8 inch
UB _a Length	13 mm / 0.512 inch
UB _b Length	6 mm / 0.236 inch
Dialectric strength For supply voltage	≥ 24V: 800 V AC < 24V: 500 V AC
Max. voltage	250 V
Max. current	1.6 A / 2 A
Length tolerance	± 2.5 %, min. ± 1.5 mm / 0.059 inch
Connection type	Type 5a

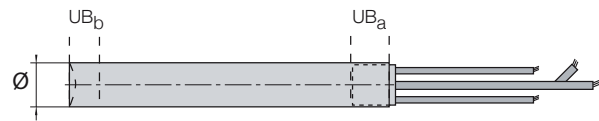

UB = Length of the unheated zone

Options

- Power distribution
- Thermocouple, ungrounded
type J or K (IEC / ANSI color codes),
measuring point at bottom, up to 80 mm heater length
- Diameter tolerances up to -0.02 -0.04 mm
- Option up to 650 °C
(only with high temperature resistant leads)

hotrod® HHP Ø 6.0 – 20 mm High Power Cartridge Heater

Specifications	
For metric sizes:	1500 mm
Max. length / Ø-tolerance	Ø-tolerance -0.02 mm -0.06 mm 3000 mm Ø-tolerance ± 0.1 mm
For imperial sizes:	59 inch
Max. length / Ø-tolerance	Ø-tolerance ± 0.79 mil 118 inch Ø-tolerance ± 3.94 mil
Length tolerance	± 1.5 %, min. ± 1.0 mm / 0.039 inch
UB _a Length	4 to 20 mm / 0.157 to 0.787 inch
UB _b Length	4 to 9 mm / 0.157 to 0.354 inch

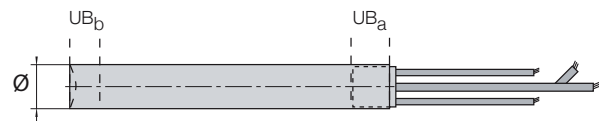

UB = Length of the unheated zone



Options

- Certified according to UL and CSA standards
- Wattage distribution
- Thermocouple, grounded or ungrounded
type J or K (IEC / ANSI color codes)
measuring point at the bottom or in the middle
- Ground lead
- Moisture protection up to IP67
- Various connection options
- Various attachments
- Diameter tolerances up to -0.02 -0.04 mm

Express-Service

Order by 10:00 a.m CET / CEST, following hotrod are ready for shipping from HQ Germany within:

- 24 hours: Ø 6.5 mm to 10.0 mm Ø ¼ inch to ⅜ inch
- 48 hours: Ø 12.5 mm to 20.0 mm Ø ½ inch to ⅝ inch
- Max. order quantity: 20 pcs.
- Max. length: 1,000 mm / 39 inch

Available Connection types

- Max. lead length mounted externally: 2.000 mm
- Max. lead length mounted internally: 1.500 mm
- With PTFE-disc: requires 48 hours
- With ceramic sealing: requires 48 hours

Options not available

- Epoxy or silicone sealing
- Multicore silicone cables
- Thermocouples grounded

hotrod® LHT

Low Power Cartridge Heater

- For lower surface loads with max. 10 W/cm²
- Cost effective heating with a long lifespan

Specifications	
Diameter	6.5 / 8.0 / 10.0 / 12.5 / 16.0 / 20.0
Max. sheath temperature	750 °C / 1380 °F
Max. sheath surface load	10 W/cm ² / 64 W/inch ²
Max. length	3000 mm / 118 inch
Length tolerance	± 1.5 %, min. ± 1.5 mm / 0.059 inch

Options

- Moisture protection
- Various connection options
- In case of extra low voltage, current return via the cartridge sheath is possible
- No high voltage test and no insulation resistance in case of current return via the cartridge sheath (only extra low voltage)
- Connection leads attached to each end of the cartridge possible
- Certified according to UL and CSA standards



UB = Length of the unheated zone

hotrod® LHT bendable

Low Power Cartridge Heater

Specifications	
Diameter	6.5 or 8.0
Sheath material	nickel or stainless steel
Max. sheath temperature	700 °C / 1292 °F
Max. sheath surface load	10 W/cm ² / 64 W/inch ²
Max. length	3000 mm / 118 inch
Length tolerance	± 1.5 %, min. ± 1.5 mm / 0.059 inch
Diameter tolerance	± 0.2 mm / 0.008 inch
Connection	glass silk insulated Ni-leads mounted externally
Min. bending radius	15 mm / 0.59 inch (internal)

No high voltage test and no insulation resistance in case of current return via the cartridge sheath (only extra low voltage).

Options

- Moisture protection
- Various connection options
- Certified according to UL and CSA standards

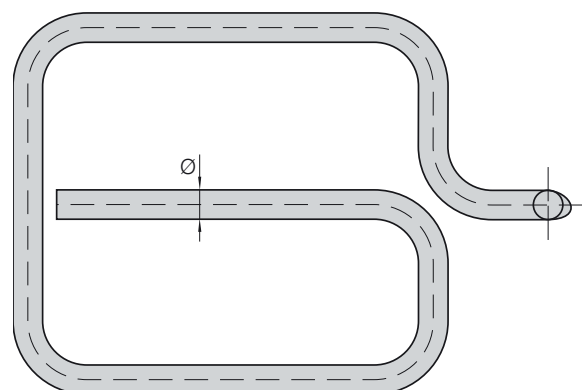
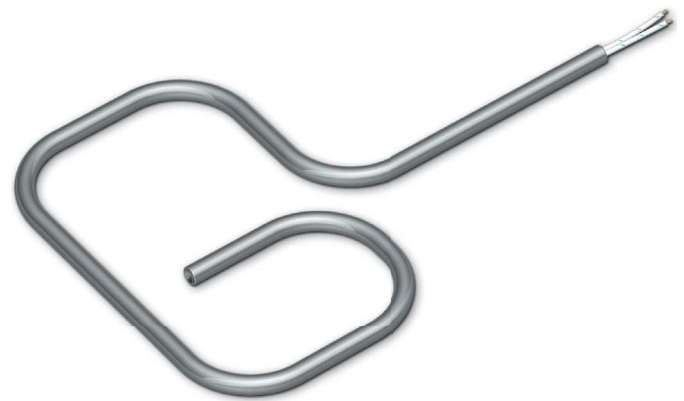

hotrod® LHT Knife Cartridge Low Power Cartridge Heater

- Cutting knife for textiles and foils

Specifications	
Diameter	5.0 mm / 0.197 inch 6.5 mm / 0.256 inch
Sheath material	Incoloy
Max. sheath temperature	950 °C / 1742 °F
Max. sheath surface load	15 W/cm ² / 96 W/inch ²
Diameter tolerance	± 0.1 mm / 0.059 inch
Max. connection voltage	24 V, with current return via sheath
Connection options	connection pin
Cutting knife	wear-resistant hard metal alloy, pre-formed, ungrinded
Min. bending radius	12.5 mm / 0.049 inch (internal)

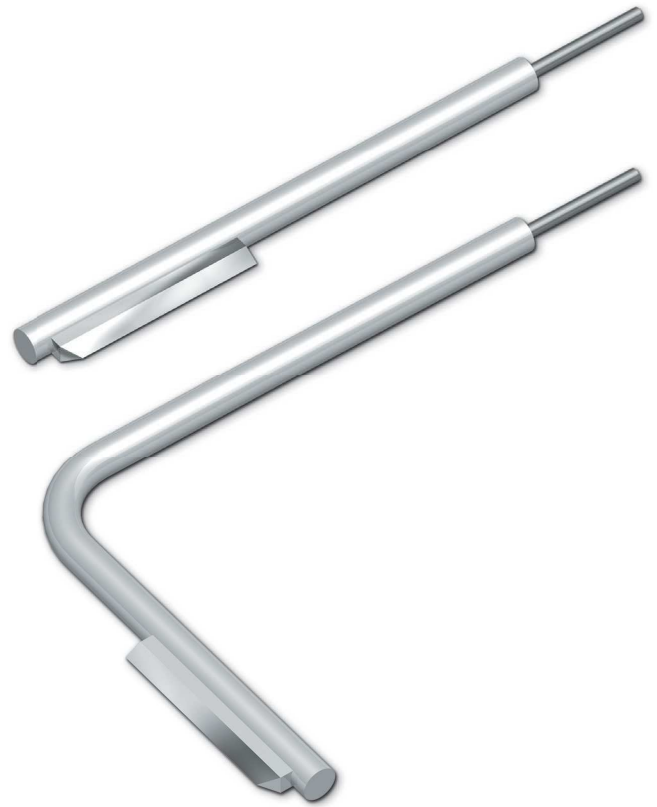

Options

- Manufactured straight or bent

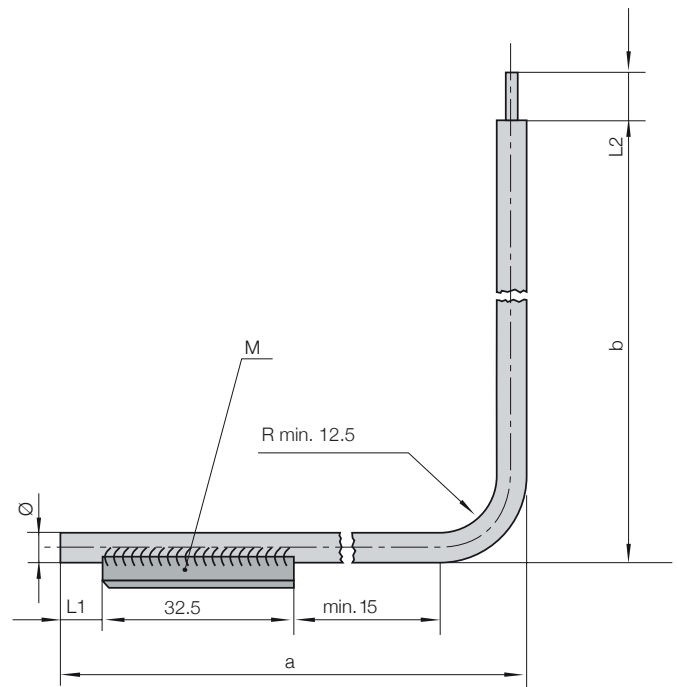

M = Cutting knife
a, b, L1, L2 = Variable length
R = Inner bending radius
All dimensions in mm

Connection with leads mounted externally

Type 1

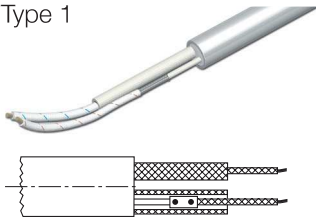

Leads mounted externally, max. 230 °C / 446 °F siliconized lead, 180 °C / 356 °F

Type 2

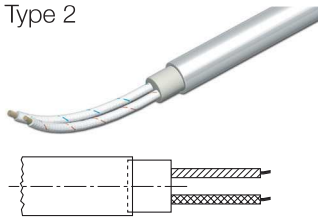

Ceramic head, any leads, see "Connection leads"

Option for Type 3 (for all)

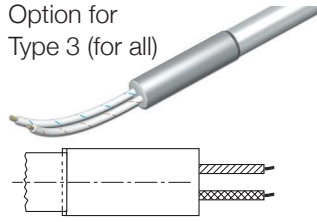

Tube section 40 mm instead of ring sleeve, e.g. with large lead cross sections (25 mm tube section on request)

Type 3a

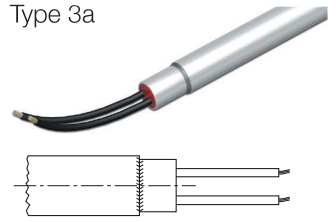

Ring sleeve, silicone leads, sealed with silicone, moisture protected, max. 180 °C / 356 °F, UL rated: max. 150 °C / 302 °F

Type 3b

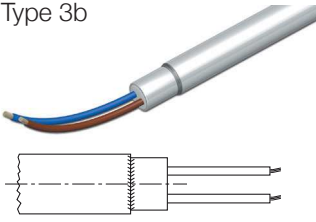

Ring sleeve, PTFE leads, sealed with epoxy resin, moisture protected, max. 250 °C / 482 °F, UL rated: max. 130 °C / 266 °F

Type 3c

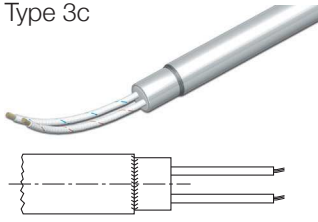

Ring sleeve, GLS leads, ceramic sealing, max. 320 °C / 608 °F

Type 6

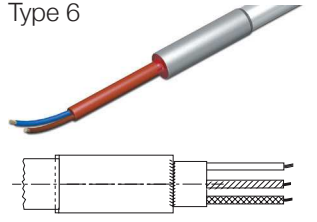

Multi core silicone cable with tube section 40 mm, sealed with silicone, moisture protected, Max. 180 °C / 356 °F, UL rated max. 150 °C / 302 °F

Connection with leads mounted internally

Type 4

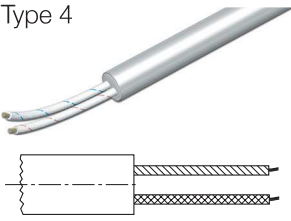

Any Leads, with ceramic closure, max. 320 °C / 608 °F

Type 5a

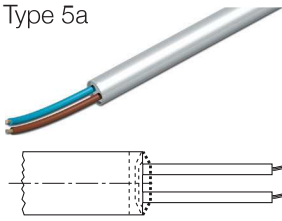

PTFE disc*, PTFE leads, max. 260 °C / 500 °F, UL rated: max 150 °C / 302 °F

Type 5b

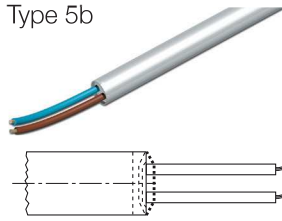

PTFE disc*, IP67 up to 40 W/cm² / 258 W/inch², max. 350 °C / 662 °F at sheath, 260 °C / 500 °F at leads, UL rated: max 180 °C / 355 °F

Type 5c

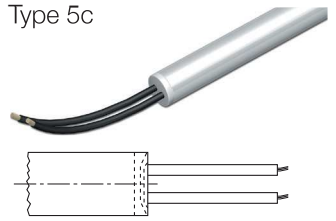

Silicone disc, silicone leads, max. 180 °C / 356 °F, UL rated: max. 150 °C / 302 °F

* PTFE disc can extend length by 1.5 mm.

Connection Leads

Glass silk insulated Ni-leads

max. Temp: 320 °C / 608 °F

Silicone Ni-leads

max. Temp: 180 °C / 356 °F UL rated: max. 150 °C / 302 °F

PTFE insulated Ni-leads (multi-stranded)

max. Temp: 260 °C / 500 °F UL rated: max. 180 °C / 356 °F

High temperature resistant glass silk insulated Ni-leads

max. Temp: 600 °C / 1112 °F

Bare, beaded leads (breakage risk)

max. Temp: 600 °C / 1112 °F

Sleeves

GLS sleeving

Braided metal sleeving

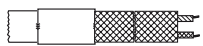

Standard ≥ Ø 8 mm



Option: ≥ Ø 10 mm
≥ 3/8 inch



Special: Ø 6.5 mm

(Examples)



Flexible metal sleeving

Stainless steel sleeving,
moisture proof

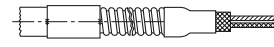

Flexible metal:
Standard ≥ Ø 6.5 mm

Stainless steel:
Standard ≥ Ø 10 mm, 3/8 inch

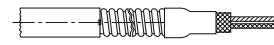

Flexible metal: Option ≥ Ø 10 mm, 3/8 inch
Stainless steel: Option ≥ Ø 12.5 mm

(Examples)



Right Angle Attachments*

Angular block

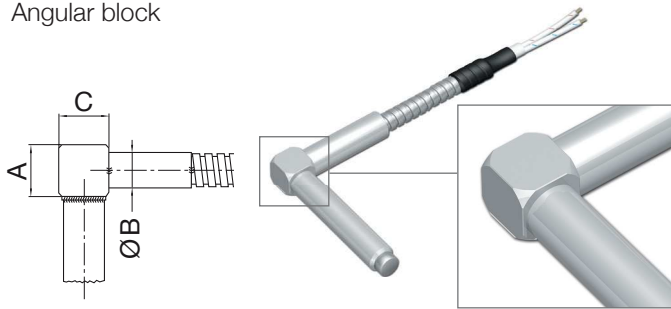

Ø hotrod	Ø B [mm]	A/C [mm]
6.5 mm	7.5	10.0
8.0 mm	9.0	10.0
10.0 mm	11.0	14.0
12.5 mm	11.0	14.0
16.0 mm	14.0	18.0
20.0 mm	18.0	25.0
1/4"	7.5	10.0
3/8"	11.0	14.0
1/2"	11.0	14.0
5/8"	14.0	18.0
3/4"	18.0	25.0

Bent pipe

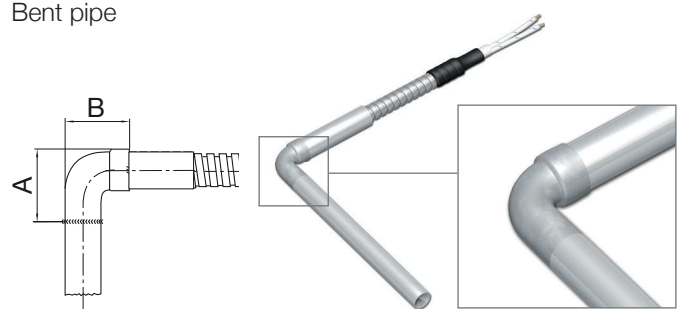

Ø hotrod	A [mm]	B [mm]
6.5 mm	15.15	15.15
8.0 mm	19.1	15.0
10.0 mm	22.6	19.0
12.5 mm	26.1	22.0
16.0 mm	34.1	29.0
20.0 mm	39.6	35.0
1/4"	15.15	15.15
3/8"	22.6	19.0
1/2"	26.1	22.0
5/8"	34.1	29.0
3/4"	39.0	35.0

Right angle exit

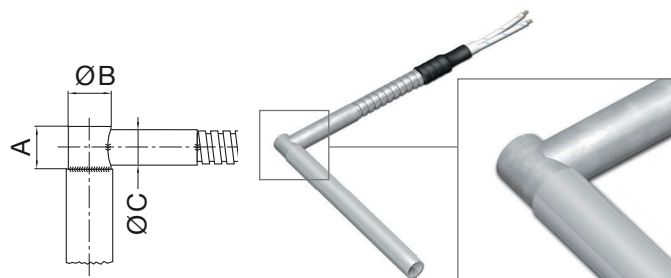

Ø hotrod	A [mm]	B [mm]	C [mm]
8.0 mm	10.0	7.5	7.5
10.0 mm	11.0	9.0	9.0
12.5 mm	13.0	12.0	11.0
16.0 mm	16.0	15.0	14.0
20.0 mm	18.0	19.5	18.0
3/8"	11.0	9.0	9.0
1/2"	13.0	12.0	11.0
5/8"	16.0	15.0	14.0
3/4"	18.0	18.5	18.0

* Remarks

- All attachments are mounted at the unheated zone of the heater
- Please state immersion depth with order

Flange and Threaded Nipple Attachments*

Threaded nipple

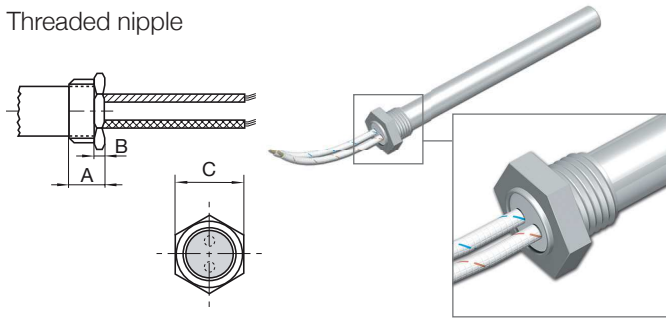

Ø hotrod	A [mm]	B [mm]	C [mm]	Thread
6.5 mm	10.0	4.0	12	M10 x 1.0 mm
8.0 mm	10.0	4.0	14	M12 x 1.0 mm
10.0 mm	12.0	4.0	17	M14 x 1.5 mm
12.5 mm	12.0	4.0	19	M16 x 1.5 mm
16.0 mm	12.0	4.0	24	M20 x 1.5 mm
20.0 mm	14.0	4.0	27	M26 x 1.5 mm
1/4"	10.0	4.0	12	G 1/8"
3/8"	12.0	4.0	17	G 1/4"
1/2"	12.0	4.0	19	G 3/8"
5/8"	12.0	4.0	24	G 1/2"

Threaded nipple with removal aid

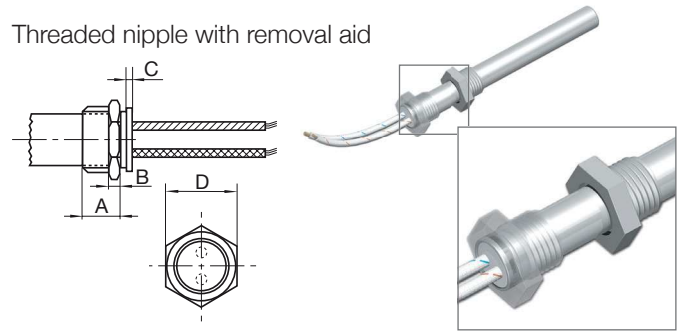

Ø hotrod	A [mm]	B [mm]	C [mm]	D [mm]	Thread
6.5 mm	10.0	4.0	2.5	12	M10 x 1.0 mm
8.0 mm	10.0	4.0	2.5	14	M12 x 1.0 mm
10.0 mm	12.0	4.0	2.5	17	M14 x 1.5 mm
12.5 mm	12.0	4.0	2.5	19	M16 x 1.5 mm
16.0 mm	12.0	4.0	2.5	24	M20 x 1.5 mm
20.0 mm	14.0	4.0	2.5	27	M26 x 1.5 mm
1/4"	10.0	4.0	2.5	12	G 1/8"
3/8"	12.0	4.0	2.5	17	G 1/4"
1/2"	12.0	4.0	2.5	19	G 3/8"
5/8"	12.0	4.0	2.5	24	G 1/2"

Flange

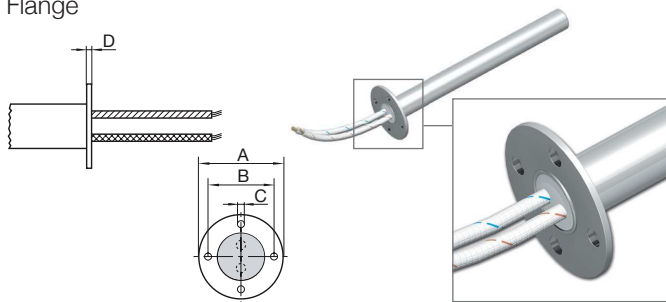

Ø hotrod	A [mm]	B [mm]	C [mm]	D [mm]
6.5 mm	18.0	13.0	2.2	1.0
8.0 mm	18.0	13.0	2.2	1.2
10.0 mm	27.0	20.0	3.2	1.2
12.5 mm	27.0	20.0	3.2	1.5
16.0 mm	33.0	25.6	3.2	1.5
20.0 mm	33.0	25.6	3.2	1.5
1/4"	18.0	13.0	2.2	1.0
3/8"	27.0	20.0	3.2	1.2
1/2"	27.0	20.0	3.2	1.2
5/8"	33.0	25.6	3.2	1.5

Mounting clamp

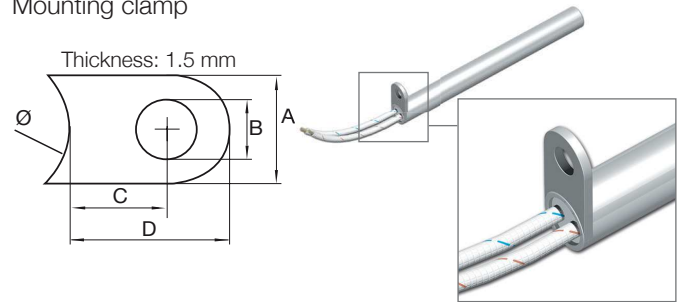

Ø hotrod [mm]	A [mm]	B [mm]	C [mm]	D [mm]
10.0	10.0	5.0	10.0	14.0
12.5	12.2	5.5	7.95	14.7
16.0	12.2	6.9	10.9	17.7
20.0	12.2	5.5	12.5	20.0

Stock Range

Stock Range HHP Ø 6.5 mm, 230 V

Stock ID	Length [mm]	Wattage [W]	Tool Preparation	Connection Type	Thermocouple
HT5210404	40	100	Press fit (DIN EN ISO 286-1)	4, GLS 1 m	Fe-CuNi Typ J
HT4010404	40	100	Press fit (DIN EN ISO 286-1)	4, GLS 1 m	
HT4010405	40	125	Press fit (DIN EN ISO 286-1)	4, GLS 1 m	
HT4010410	40	160	Press fit (DIN EN ISO 286-1)	4, GLS 1 m	
HT4010411	40	175	Press fit (DIN EN ISO 286-1)	4, GLS 1 m	
HT4010415	40	200	Press fit (DIN EN ISO 286-1)	4, GLS 1 m	
HT4010504	50	100	H7-tolerance bore	4, GLS 1 m	
HT4010510	50	160	Press fit (DIN EN ISO 286-1)	4, GLS 1 m	
HT5210515	50	200	Press fit (DIN EN ISO 286-1)	4, GLS 1 m	Fe-CuNi Typ J
HT4010515	50	200	Press fit (DIN EN ISO 286-1)	4, GLS 1 m	
HT4010517	50	250	Press fit (DIN EN ISO 286-1)	4, GLS 1 m	
HT4010605	60	125	H7-tolerance bore	4, GLS 1 m	
HT5210615	60	200	Press fit (DIN EN ISO 286-1)	4, GLS 1 m	Fe-CuNi Typ J
HT4010615	60	200	Press fit (DIN EN ISO 286-1)	4, GLS 1 m	
HT5210617	60	250	Press fit (DIN EN ISO 286-1)	4, GLS 1 m	Fe-CuNi Typ J
HT4010617	60	250	Press fit (DIN EN ISO 286-1)	4, GLS 1 m	
HT4010805	80	125	H7-tolerance bore	4, GLS 1 m	
HT4010815	80	200	H7-tolerance bore	4, GLS 1 m	
HT4010817	80	250	Press fit (DIN EN ISO 286-1)	4, GLS 1 m	
HT4010822	80	315	Press fit (DIN EN ISO 286-1)	4, GLS 1 m	
HT4011010	100	160	H7-tolerance bore	4, GLS 1 m	
HT4011017	100	250	H7-tolerance bore	4, GLS 1 m	
HT5211023	100	350	Press fit (DIN EN ISO 286-1)	4, GLS 1 m	Fe-CuNi Typ J
HT4011023	100	350	Press fit (DIN EN ISO 286-1)	4, GLS 1 m	
HT4011316	130	220	H7-tolerance bore	4, GLS 1 m	
HT4011323	130	350	H7-tolerance bore	4, GLS 1 m	

For components subjected to a surface load of more than 20W / inch², it is necessary to use a press fit, which can be achieved by individual adjustment of the cartridge.

Final part ID may be different to stock ID

Stock Range HHP Ø 8.0 mm, 230 V

Stock ID	Length [mm]	Wattage [W]	Tool Preparation	Connection Type	Thermocouple
HT5220404	40	100	Press fit (DIN EN ISO 286-1)	4, GLS 1 m	Fe-CuNi Typ J
HT4020404	40	100	Press fit (DIN EN ISO 286-1)	4, GLS 1 m	
HT4020410	40	160	Press fit (DIN EN ISO 286-1)	4, GLS 1 m	
HT4020415	40	200	Press fit (DIN EN ISO 286-1)	4, GLS 1 m	
HT4020417	40	250	Press fit (DIN EN ISO 286-1)	4, GLS 1 m	
HT4020505	50	125	H7-tolerance bore	4, GLS 1 m	
HT4020515	50	200	Press fit (DIN EN ISO 286-1)	4, GLS 1 m	
HT5220517	50	250	Press fit (DIN EN ISO 286-1)	4, GLS 1 m	Fe-CuNi Typ J
HT4020517	50	250	Press fit (DIN EN ISO 286-1)	4, GLS 1 m	
HT4020522	50	315	Press fit (DIN EN ISO 286-1)	4, GLS 1 m	
HT4020605	60	125	H7-tolerance bore	4, GLS 1 m	
HT4020615	60	200	Press fit (DIN EN ISO 286-1)	4, GLS 1 m	
HT4020617	60	250	Press fit (DIN EN ISO 286-1)	4, GLS 1 m	
HT5220617	60	250	Press fit (DIN EN ISO 286-1)	4, GLS 1 m	Fe-CuNi Typ J
HT4020618	60	280	Press fit (DIN EN ISO 286-1)	4, GLS 1 m	
HT4020815	80	200	H7-tolerance bore	4, GLS 1 m	
HT5220822	80	315	Press fit (DIN EN ISO 286-1)	4, GLS 1 m	Fe-CuNi Typ J
HT4020822	80	315	Press fit (DIN EN ISO 286-1)	4, GLS 1 m	
HT4020826	80	400	Press fit (DIN EN ISO 286-1)	4, GLS 1 m	
HT4021015	100	200	H7-tolerance bore	4, GLS 1 m	
HT4021017	100	250	H7-tolerance bore	4, GLS 1 m	
HT5221022	100	315	Press fit (DIN EN ISO 286-1)	4, GLS 1 m	Fe-CuNi Typ J
HT4021022	100	315	H7-tolerance bore	4, GLS 1 m	
HT4021026	100	400	Press fit (DIN EN ISO 286-1)	4, GLS 1 m	
HT4021317	130	250	H7-tolerance bore	4, GLS 1 m	
HT4021322	130	315	H7-tolerance bore	4, GLS 1 m	
HT5221326	130	400	Press fit (DIN EN ISO 286-1)	4, GLS 1 m	Fe-CuNi Typ J
HT4021326	130	400	H7-tolerance bore	4, GLS 1 m	
HT4021615	160	200	H7-tolerance bore	4, GLS 1 m	

For components subjected to a surface load of more than 20W / inch², it is necessary to use a press fit, which can be achieved by individual adjustment of the cartridge.

Final part ID may be different to stock ID

Stock Range HHP Ø 10.0 mm, 230 V

Stock ID	Length [mm]	Wattage [W]	Tool Preparation	Connection Type	Thermocouple
HT4030404	40	100	H7-tolerance bore	4, GLS 1 m	
HT4030405	40	125	Press fit (DIN EN ISO 286-1)	4, GLS 1 m	
HT5230415	40	200	Press fit (DIN EN ISO 286-1)	4, GLS 1 m	Fe-CuNi Typ J
HT4030415	40	200	Press fit (DIN EN ISO 286-1)	4, GLS 1 m	
HT4030422	40	315	Press fit (DIN EN ISO 286-1)	4, GLS 1 m	
HT4030504	50	100	H7-tolerance bore	4, GLS 1 m	
HT4030510	50	160	H7-tolerance bore	4, GLS 1 m	
HT4030515	50	200	Press fit (DIN EN ISO 286-1)	4, GLS 1 m	
HT5230517	50	250	Press fit (DIN EN ISO 286-1)	4, GLS 1 m	Fe-CuNi Typ J
HT4030517	50	250	Press fit (DIN EN ISO 286-1)	4, GLS 1 m	
HT4030526	50	400	Press fit (DIN EN ISO 286-1)	4, GLS 1 m	
HT4030612	60	180	H7-tolerance bore	4, GLS 1 m	
HT5230617	60	250	Press fit (DIN EN ISO 286-1)	4, GLS 1 m	Fe-CuNi Typ J
HT4030617	60	250	Press fit (DIN EN ISO 286-1)	4, GLS 1 m	
HT4030622	60	315	Press fit (DIN EN ISO 286-1)	4, GLS 1 m	
HT4030626	60	400	Press fit (DIN EN ISO 286-1)	4, GLS 1 m	
HT4030630	60	500	Press fit (DIN EN ISO 286-1)	4, GLS 1 m	
HT4030810	80	160	H7-tolerance bore	4, GLS 1 m	
HT5230817	80	250	Press fit (DIN EN ISO 286-1)	4, GLS 1 m	Fe-CuNi Typ J
HT4030817	80	250	H7-tolerance bore	4, GLS 1 m	
HT4030822	80	315	H7-tolerance bore	4, GLS 1 m	
HT4030826	80	400	Press fit (DIN EN ISO 286-1)	4, GLS 1 m	
HT4030830	80	500	Press fit (DIN EN ISO 286-1)	4, GLS 1 m	
HT4030835	80	630	Press fit (DIN EN ISO 286-1)	4, GLS 1 m	
HT4031016	100	220	H7-tolerance bore	4, GLS 1 m	
HT4031017	100	250	H7-tolerance bore	4, GLS 1 m	
HT4031022	100	315	H7-tolerance bore	4, GLS 1 m	
HT5231023	100	350	Press fit (DIN EN ISO 286-1)	4, GLS 1 m	Fe-CuNi Typ J
HT4031023	100	350	H7-tolerance bore	4, GLS 1 m	
HT4031026	100	400	H7-tolerance bore	4, GLS 1 m	
HT4031030	100	500	Press fit (DIN EN ISO 286-1)	4, GLS 1 m	
HT4031035	100	630	Press fit (DIN EN ISO 286-1)	4, GLS 1 m	
HT4031044	100	850	Press fit (DIN EN ISO 286-1)	4, GLS 1 m	
HT4031322	130	315	H7-tolerance bore	4, GLS 1 m	
HT4031326	130	400	H7-tolerance bore	4, GLS 1 m	
HT4031330	130	500	H7-tolerance bore	4, GLS 1 m	
HT4031335	130	630	Press fit (DIN EN ISO 286-1)	4, GLS 1 m	
HT4031343	130	800	Press fit (DIN EN ISO 286-1)	4, GLS 1 m	
HT5231626	160	400	H7-tolerance bore	4, GLS 1 m	Fe-CuNi Typ J
HT4031626	160	400	H7-tolerance bore	4, GLS 1 m	
HT5231635	160	630	Press fit (DIN EN ISO 286-1)	4, GLS 1 m	Fe-CuNi Typ J
HT4031635	160	630	H7-tolerance bore	4, GLS 1 m	
HT4032026	200	400	H7-tolerance bore	4, GLS 1 m	
HT4032035	200	630	H7-tolerance bore	4, GLS 1 m	

For components subjected to a surface load of more than 20W / inch², it is necessary to use a press fit, which can be achieved by individual adjustment of the cartridge.

Final part ID may be different to stock ID

Stock Range HHP Ø 12.5 mm, 230 V

Stock ID	Length [mm]	Wattage [W]	Tool Preparation	Connection Type	Thermocouple
HT4050417	40	250	Press fit (DIN EN ISO 286-1)	4, GLS 1 m	
HT4050426	40	400	Press fit (DIN EN ISO 286-1)	4, GLS 1 m	
HT4050615	60	200	H7-tolerance bore	4, GLS 1 m	
HT4050622	60	315	Press fit (DIN EN ISO 286-1)	4, GLS 1 m	
HT4050817	80	250	H7-tolerance bore	4, GLS 1 m	
HT4050822	80	315	H7-tolerance bore	4, GLS 1 m	
HT4050830	80	500	H7-tolerance bore	4, GLS 1 m	
HT4050835	80	630	Press fit (DIN EN ISO 286-1)	4, GLS 1 m	
HT4050843	80	800	Press fit (DIN EN ISO 286-1)	4, GLS 1 m	
HT4051026	100	400	H7-tolerance bore	4, GLS 1 m	
HT5251030	100	500	Press fit (DIN EN ISO 286-1)	4, GLS 1 m	Fe-CuNi Typ J
HT4051030	100	500	H7-tolerance bore	4, GLS 1 m	
HT4051035	100	630	Press fit (DIN EN ISO 286-1)	4, GLS 1 m	
HT4051043	100	800	Press fit (DIN EN ISO 286-1)	4, GLS 1 m	
HT4051326	130	400	H7-tolerance bore	4, GLS 1 m	
HT4051330	130	500	H7-tolerance bore	4, GLS 1 m	
HT4051335	130	630	H7-tolerance bore	4, GLS 1 m	
HT4051343	130	800	Press fit (DIN EN ISO 286-1)	4, GLS 1 m	
HT4051352	130	1250	Press fit (DIN EN ISO 286-1)	4, GLS 1 m	
HT4051630	160	500	H7-tolerance bore	4, GLS 1 m	
HT4051635	160	630	H7-tolerance bore	4, GLS 1 m	
HT4051643	160	800	H7-tolerance bore	4, GLS 1 m	
HT4051836	180	670	H7-tolerance bore	4, GLS 1 m	
HT4051850	180	1000	H7-tolerance bore	4, GLS 1 m	
HT4052035	200	630	H7-tolerance bore	4, GLS 1 m	
HT4052043	200	800	H7-tolerance bore	4, GLS 1 m	
HT4052047	200	900	H7-tolerance bore	4, GLS 1 m	
HT4052543	250	800	H7-tolerance bore	4, GLS 1 m	
HT4052547	250	900	H7-tolerance bore	4, GLS 1 m	

For components subjected to a surface load of more than 20W / inch², it is necessary to use a press fit, which can be achieved by individual adjustment of the cartridge.

Final part ID may be different to stock ID

Stock Range HHP Ø 16.0 mm, 230 V

Stock ID	Length [mm]	Wattage [W]	Tool Preparation	Connection Type	Thermocouple
HT4060417	40	250	Press fit (DIN EN ISO 286-1)	4, GLS 1 m	
HT4060615	60	200	H7-tolerance bore	4, GLS 1 m	
HT4060622	60	315	H7-tolerance bore	4, GLS 1 m	
HT4060626	60	400	Press fit (DIN EN ISO 286-1)	4, GLS 1 m	
HT4060826	80	400	H7-tolerance bore	4, GLS 1 m	
HT4060830	80	500	H7-tolerance bore	4, GLS 1 m	
HT4060835	80	630	Press fit (DIN EN ISO 286-1)	4, GLS 1 m	
HT4060843	80	800	Press fit (DIN EN ISO 286-1)	4, GLS 1 m	
HT4061026	100	400	H7-tolerance bore	4, GLS 1 m	
HT4061030	100	500	H7-tolerance bore	4, GLS 1 m	
HT4061035	100	630	H7-tolerance bore	4, GLS 1 m	
HT4061043	100	800	Press fit (DIN EN ISO 286-1)	4, GLS 1 m	
HT4061050	100	1000	Press fit (DIN EN ISO 286-1)	4, GLS 1 m	
HT4061330	130	500	H7-tolerance bore	4, GLS 1 m	
HT4061335	130	630	H7-tolerance bore	4, GLS 1 m	
HT4061343	130	800	H7-tolerance bore	4, GLS 1 m	
HT4061347	130	1000	Press fit (DIN EN ISO 286-1)	4, GLS 1 m	
HT4061635	160	630	H7-tolerance bore	4, GLS 1 m	
HT4061643	160	800	H7-tolerance bore	4, GLS 1 m	
HT4061650	160	1000	H7-tolerance bore	4, GLS 1 m	
HT4061652	160	1250	H7-tolerance bore	4, GLS 1 m	
HT4061852	180	1250	H7-tolerance bore	4, GLS 1 m	
HT4062030	200	500	H7-tolerance bore	4, GLS 1 m	
HT4062043	200	800	H7-tolerance bore	4, GLS 1 m	
HT4062050	200	1000	H7-tolerance bore	4, GLS 1 m	
HT4062052	200	1250	H7-tolerance bore	4, GLS 1 m	
HT4062061	200	2000	Press fit (DIN EN ISO 286-1)	4, GLS 1 m	
HT4062550	250	1000	H7-tolerance bore	4, GLS 1 m	
HT4062552	250	1250	H7-tolerance bore	4, GLS 1 m	
HT4062555	250	1600	H7-tolerance bore	4, GLS 1 m	
HT4063050	300	1000	H7-tolerance bore	4, GLS 1 m	
HT4063052	300	1250	H7-tolerance bore	4, GLS 1 m	
HT4063054	300	1500	H7-tolerance bore	4, GLS 1 m	
HT4063056	300	1800	H7-tolerance bore	4, GLS 1 m	

For components subjected to a surface load of more than 20W / inch², it is necessary to use a press fit, which can be achieved by individual adjustment of the cartridge.

Final part ID may be different to stock ID

Stock Range HHP Ø 20.0 mm, 230 V

Stock ID	Length [mm]	Wattage [W]	Tool Preparation	Connection Type	Thermocouple
HT4070622	60	315	H7-tolerance bore	4, GLS 1 m	
HT4070843	80	800	Press fit (DIN EN ISO 286-1)	4, GLS 1 m	
HT4071050	100	1000	Press fit (DIN EN ISO 286-1)	4, GLS 1 m	
HT4071643	160	800	H7-tolerance bore	4, GLS 1 m	
HT4071650	160	1000	H7-tolerance bore	4, GLS 1 m	
HT4072050	200	1000	H7-tolerance bore	4, GLS 1 m	
HT4072055	200	1600	H7-tolerance bore	4, GLS 1 m	
HT4072552	250	1250	H7-tolerance bore	4, GLS 1 m	
HT4072561	250	2000	H7-tolerance bore	4, GLS 1 m	
HT4073055	300	1600	H7-tolerance bore	4, GLS 1 m	
HT4073062	300	2200	H7-tolerance bore	4, GLS 1 m	

For components subjected to a surface load of more than 20W / inch², it is necessary to use a press fit, which can be achieved by individual adjustment of the cartridge.

Final part ID may be different to stock ID

Stock Range HHP Ø 1/4" (Ø 6.3 mm), 230 V

Stock ID	Length [inch]	Wattage [W]	Tool Preparation	Connection Type	Thermocouple
HT4110305	1 1/2	125	Press fit (DIN EN ISO 286-1)	4, GLS 1 m	
HT5310311	1 1/2	175	Press fit (DIN EN ISO 286-1)	4, GLS 1 m	Fe-CuNi Typ J
HT4110311	1 1/2	175	Press fit (DIN EN ISO 286-1)	4, GLS 1 m	
HT4110315	1 1/2	200	Press fit (DIN EN ISO 286-1)	4, GLS 1 m	
HT4110505	2	125	Press fit (DIN EN ISO 286-1)	4, GLS 1 m	
HT5310515	2	200	Press fit (DIN EN ISO 286-1)	4, GLS 1 m	Fe-CuNi Typ J
HT4110515	2	200	Press fit (DIN EN ISO 286-1)	4, GLS 1 m	
HT5310617	2 1/2	250	Press fit (DIN EN ISO 286-1)	4, GLS 1 m	Fe-CuNi Typ J
HT4110617	2 1/2	250	Press fit (DIN EN ISO 286-1)	4, GLS 1 m	
HT5310721	3	300	Press fit (DIN EN ISO 286-1)	4, GLS 1 m	Fe-CuNi Typ J
HT4111023	4	350	Press fit (DIN EN ISO 286-1)	4, GLS 1 m	

Stock Range HHP Ø 3/8" (Ø 9.46 mm), 230 V

Stock ID	Length [inch]	Wattage [W]	Tool Preparation	Connection Type	Thermocouple
HT4130315	1 1/2	200	Press fit (DIN EN ISO 286-1)	4, GLS 1 m	
HT4130317	1 1/2	250	Press fit (DIN EN ISO 286-1)	4, GLS 1 m	
HT4130517	2	250	Press fit (DIN EN ISO 286-1)	4, GLS 1 m	
HT4130726	3	400	Press fit (DIN EN ISO 286-1)	4, GLS 1 m	
HT4131030	4	500	Press fit (DIN EN ISO 286-1)	4, GLS 1 m	
HT4131230	5	500	H7-tolerance bore	4, GLS 1 m	
HT4131530	6	500	H7-tolerance bore	4, GLS 1 m	

Stock Range HHP Ø 1/2" (Ø 12.61 mm), 230 V

Stock ID	Length [inch]	Wattage [W]	Tool Preparation	Connection Type	Thermocouple
HT4150726	3	400	H7-tolerance bore	4, GLS 1 m	
HT4150730	3	500	Press fit (DIN EN ISO 286-1)	4, GLS 1 m	
HT4151030	4	500	H7-tolerance bore	4, GLS 1 m	
HT4151240	5	750	H7-tolerance bore	4, GLS 1 m	
HT4151530	6	500	H7-tolerance bore	4, GLS 1 m	
HT4152050	8	1000	H7-tolerance bore	4, GLS 1 m	

Stock Range HHP Ø 5/8" (Ø 15.81 mm), 230 V

Stock ID	Length [inch]	Wattage [W]	Tool Preparation	Connection Type	Thermocouple
HT4161550	6	1000	H7-tolerance bore	4, GLS 1 m	

For components subjected to a surface load of more than 20W / inch², it is necessary to use a press fit, which can be achieved by individual adjustment of the cartridge.

Final part ID may be different to stock ID



hotset

Hotset GmbH
Hueckstraße 16
58511 Lüdenscheid
Germany

Phone +49 / 23 51 / 43 02-0
Fax +49 / 23 51 / 43 02-25

www.hotset.com