

# IEM<sup>®</sup>

## WEAR PRODUCTS

- ◆ Inch & Metric Sizes
- ◆ Self-Lubricating & Standard Models

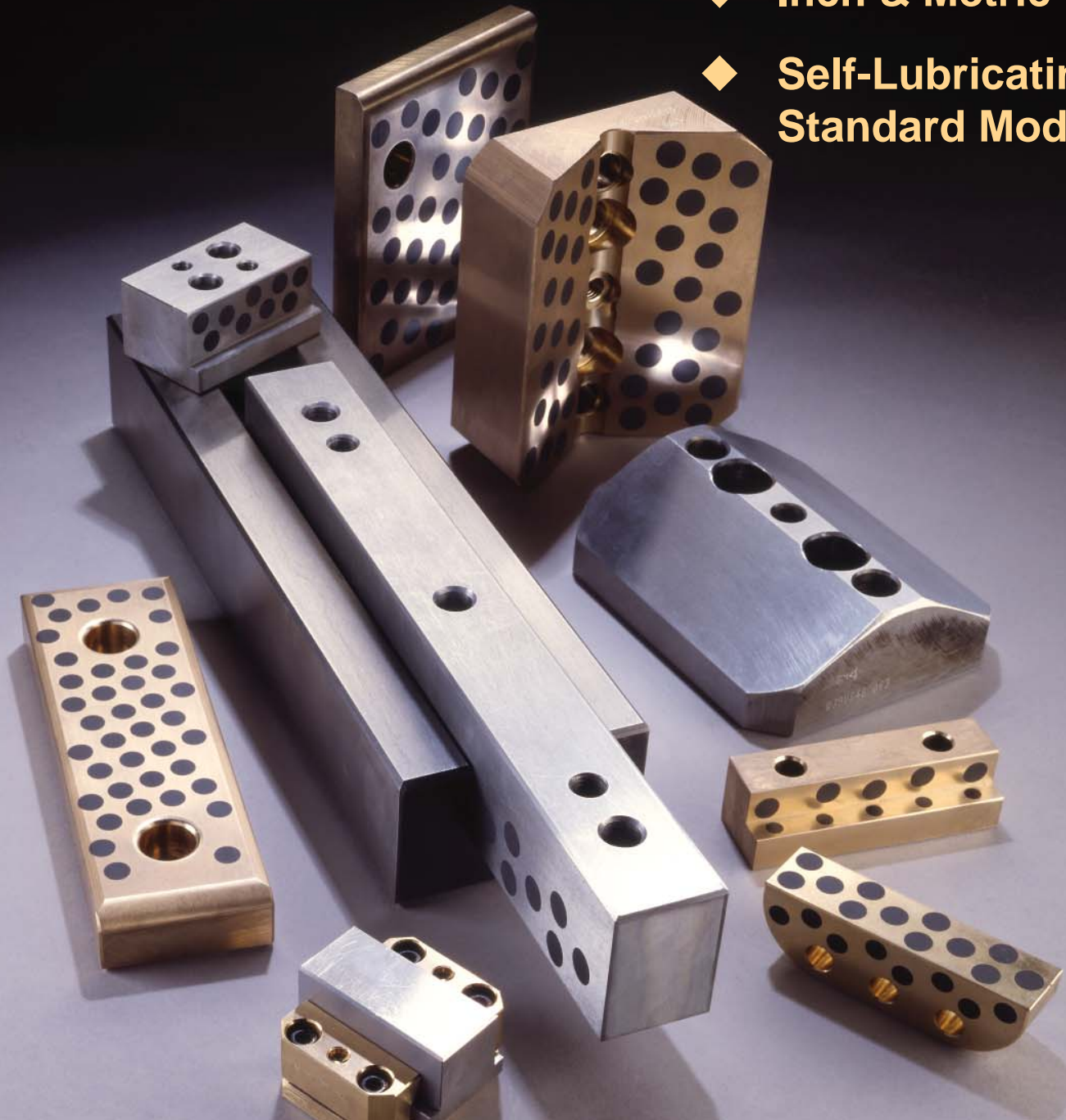

# WEAR PRODUCTS

## SERVICE WE DELIVER AND QUALITY YOU CAN DEPEND ON

**IEM** is a leading manufacturer of die and mold components supplied globally to the parts forming industry. Backed by years of tool and die experience, quality and innovation are some of the reasons why our name is respected throughout the world. We have taken the lead role in creating and bringing new products to customers and helping them find solutions that improve their operations. Based on the capabilities **IEM** offers, we can help you to meet the demands of quick deliveries, technical support, quality products and competitive prices. **IEM** and its' broad distribution channels and direct sales personnel will assist you in any way to make your product a better and more profitable one.

Whether standard or customized products, with our years of experience, customers can be sure the products they receive will meet their expectations for reliability and dependable performance. We understand the demanding schedules of die builders and production personnel and have developed efficient manufacturing processes to shorten product lead times as well as put inventory on our shelves so you can have it in your facility when you need it.

Included in our full line offering are both inch and metric size die components that are designed to die standards including ISO, NAAMS, JIS and many automotive and appliance manufacturers' standards. The complete product offering includes:

- Accu-Bend™ Rotary Benders
- Air Presses
- Cams
  - Aerial & Diemount Cams
  - Box & Bump Cams
  - Roller Cams
  - Wide Cams
- Die Accessories
- Guide Posts & Bushings
  - Plain & Ball Bearing Styles
  - Steel, Bronze, Bronze-Plated & Self-Lubricating Bushings
  - Lempscoloy Bushings
  - Special Pins, Bushings & Retainers
- Hydraulics
  - Electronic Die Setters
  - Die Separators
  - Drill & Tap Equipment
  - Hydraulic Motors
- In-Die Tapping Units
- Mold Components
  - Bronze Plated & Self-Lubricated Bushings
  - Leader Pins
  - Bronze & Bronze Plated Wear Strips & Ways
- Punches, Buttons & Retainers
- Springs
  - DieMax L Inch Series Springs
  - DieMax XL Series ISO Springs
  - JIS Series Springs
  - Custom Heavy Duty Springs
  - Marsh Mellow Springs
  - Formathane Urethane
  - Kaller Gas Springs
  - Utility & Disc Springs
- Wear Products
  - Plates, Strips, Gibs & Blocks
  - Steel, bronze, Bronze-Plated and Self-Lubricating Materials

# CONTENTS

	PAGE NUMBER	
	<u>INCH</u>	<u>METRIC</u>
<b>Wear Plates</b>		
Wear Plate Installation & Selection Guide	1	
N-Series Standard & Self-Lubricating Wear Plates	2	
NAAMS Series W01, W02 & W03		
Standard & Self-Lubricating Wear Plates		4
JIS Series Standard & Self-Lubricating Wear Plates		6
NAAMS Series W05, W06 & W07/VDI 3357 Wear Plates		8
Automotive Wear Plate Conversions		10
<b>Wearstrips</b>		
Plain Bronze & Self-Lubricating Wearstrips		
with Mounting Holes	12	
Self-Lubricating Wearstrip Ways	15	
Plain Bronze & Self-Lubricating Wearstrips		
without Mounting Holes	16	
NAAMS Series Self-Lubricating Wearstrips		18
NW Series Self-Lubricating Wearstrips		20
<b>Gibs &amp; Gib Assemblies</b>		
Self-Lubricating Gib Assemblies	21	
Self-Lubricating L-Gibs for Gib Assembly	22	
Self-Lubricating Baseplate for Gib Assembly	23	
Optional T-Slide for Gib Assembly	24	
Self-Lubricating Square Gibs	25	
Self-Lubricating L-Gibs	26	
Self-Lubricating L-Gibs		27
Self-Lubricating 10mm LIP Cam Slide Gibs		28
Self-Lubricating 13mm LIP Cam Slide Gibs		29
<b>Guide Blocks</b>		
Self-Lubricating U & V Blocks	30	
NAAMS U & V Blocks		32
Self-Lubricating 45mm Guide Blocks		34
Self-Lubricating 60mm Guide Blocks		36
Medium Duty Self-Lubricating Guide Blocks	38	
Self-Lubricating Metric Corner Guide Blocks		40
Self-Lubricating Center Key & Guide		41

# CONTENTS

---

	PAGE NUMBER	
	<u>INCH</u>	<u>METRIC</u>
<b>Keeper Plates &amp; Blocks</b>		
Self-Lubricating Keeper Plates	42	
Self-Lubricating Metric Keeper Plates		43
Light Duty K-Series Self-Lubricating Keeper Blocks	44	
Medium Duty KM-Series Self-Lubricating Keeper Blocks	46	
Heavy Duty KH-Series Self-Lubricating Keeper Block	48	
Self-Lubricating 6mm LIP Keeper Blocks		50
Self-Lubricating 13mm LIP Keeper Blocks		52
<b>Cam Dwells</b>		
Self-Lubricating Cam Dwell Wearplates	54	
<b>Stop Blocks &amp; Retainers</b>		
Stop Blocks	55	
Pad Retainers – Locking, Standard Mount	56	
Pad Retainers – Locking, Standard Mount with Flats	58	
Pad Retainers – Locking, Reverse Mount with Flats	60	
Pad Retainers – Standard Mount		61
Pad Retainers – Reverse Mount		62

# Wear Plate Installation & Selection Guide

---

## Steel with Graphite Plugs & Aluminum Bronze with Graphite Plugs

1. When installing and/or after cleaning, we recommend that a coat of 20 wt. oil be applied to the wear surface to help start the lubricating process.
2. If grinding is necessary, grind only the back or edges of the wear plate, not the plugged side of the wear plate.
3. It is not necessary to lubricate the wear plate after the initial coat of oil is applied.

## Plain Steel & Steel with Graphite Plugs

1. It is important that wet grinding techniques be used if grinding is necessary.
2. When wet grinding, do not remove more than .0002" to .0004" (0.005 to 0.010mm) at each pass.

**FAILURE TO COMPLY WITH THESE RECOMMENDATIONS  
MAY RESULT IN CRACKING OF THE WEAR PLATE**

## Recommended Conditions for Maximum Performance

1. Aluminum Bronze with graphite plugs against plain (ungrooved) steel.
2. Steel with graphite plugs against plain (ungrooved) steel.
3. Aluminum Bronze with graphite plugs against cast die – not recommended if load exceeds 300 psi (20 bar).
4. Steel with graphite plugs against cast die – not recommended if load exceeds 200 psi (13.5 bar). Must have balanced load.

# N-Series Standard & Self-Lubricating Wear Plates – Inch



## Product Features

The N-Series of wear plate is manufactured to inch dimensions. They are 1" thick and available in both hardened steel and self-lubricating aluminum-bronze materials. They are supplied with two to five mounting holes, dependent on the size, to accommodate 1/2" S.H.C.S. For ease of identification, all products are marked with the part number.

### MATERIALS:

- ◆ Steel wear plates are manufactured from high quality carburized steel. They are precision ground and hardened to Rc 56-60 (0.05 to 0.06 inches deep).
- ◆ Self lubricating wear plates are manufactured from aluminum bronze material with oil impregnated graphite plugs. The graphite plugs are arranged to generate optimal coverage at any engagement direction of the wear plate.

### TOLERANCES:

- ◆ Thickness  $\pm 0.001$  in.
- ◆ Mounting hole locations  $\pm 0.010$  in.
- ◆ Flatness  $\pm 0.0005$  in.
- ◆ Unless otherwise noted  $\pm 0.010$  in.

### MOUNTING SCREWS:

- ◆ 1/2" S.H.C.S. recommended for mounting. Plate has 9/16" through hole with 13/16" counterbore 0.56" depth.

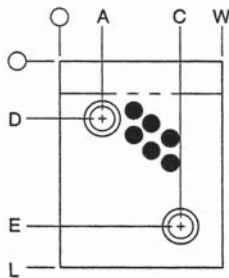
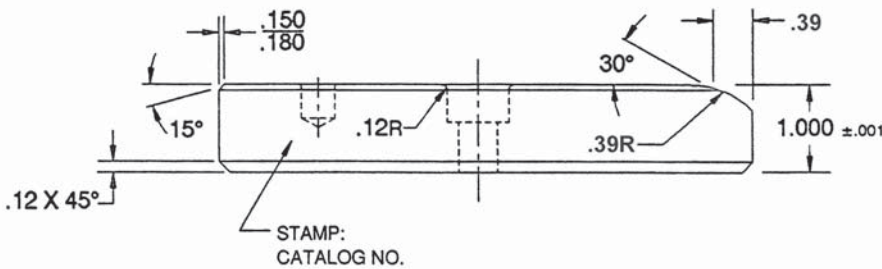

HOLE PATTERN A

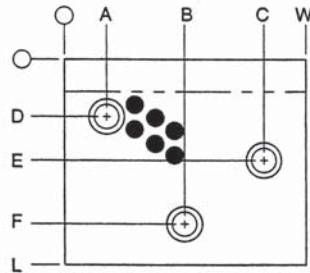

HOLE PATTERN B

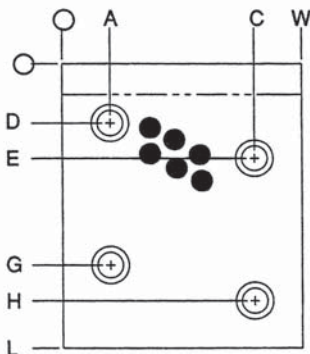

HOLE PATTERN C

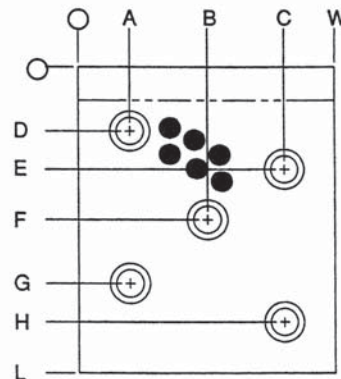

HOLE PATTERN D



# N-Series Standard & Self-Lubricating Wear Plates – Inch

Width W (in)	Length L (in)	Steel Part Number	Self- Lubricating Part #	Mounting Hole Pattern & Location									
				Hole Qty.	Hole Pattern	A (in)	B (in)	C (in)	D (in)	E (in)	F (in)	G (in)	H (in)
2.50	8.00	NSX82508	NYG82508	2	A	1.25	–	1.25	1.50	6.50	–	–	–
3	2.50	NSX83025	NYG83025	2	A	0.75	–	2.25	1.25	1.25	–	–	–
	4.00	NSX8304	NYG8304	2	A	0.75	–	2.25	1.25	2.75	–	–	–
	5.00	NSX8305	NYG8305	2	A	0.75	–	2.25	1.50	3.75	–	–	–
	6.00	NSX8306	NYG8306	2	A	0.75	–	2.25	1.50	4.50	–	–	–
	8.00	NSX8308	NYG8308	2	A	0.75	–	2.25	1.50	6.50	–	–	–
	10.00	NSX8310	NYG8310	3	B	0.75	1.50	2.25	1.50	2.50	8.50	–	–
	12.00	NSX8312	NYG8312	3	B	0.75	1.50	2.25	1.50	2.50	10.50	–	–
4	2.50	NSX84025	NYG84025	2	A	1.25	–	2.75	1.25	1.25	–	–	–
	3.00	NSX8403	NYG8403	2	A	1.00	–	3.00	1.50	2.25	–	–	–
	4.00	NSX8404	NYG8404	2	A	1.00	–	3.00	1.25	2.75	–	–	–
	5.00	NSX8405	NYG8405	2	A	0.88	–	3.12	1.50	3.75	–	–	–
	6.00	NSX8406	NYG8406	2	A	0.88	–	3.12	1.50	4.50	–	–	–
	8.00	NSX8408	NYG8408	3	B	0.88	2.00	3.12	1.50	2.50	6.50	–	–
	10.00	NSX8410	NYG8410	3	B	0.88	2.00	3.12	1.50	2.50	8.50	–	–
	12.00	NSX8412	NYG8412	3	B	0.88	2.00	3.12	1.50	2.50	10.50	–	–
5	2.50	NSX85025	NYG85025	2	A	1.25	–	3.75	1.25	1.25	–	–	–
	4.00	NSX8504	NYG8504	2	A	1.00	–	4.00	1.50	2.75	–	–	–
	5.00	NSX8505	NYG8505	2	A	1.00	–	4.00	1.50	3.75	–	–	–
	6.00	NSX8506	NYG8506	2	A	1.00	–	4.00	1.50	4.50	–	–	–
	8.00	NSX8508	NYG8508	3	B	1.00	2.50	4.00	1.50	2.50	6.50	–	–
	10.00	NSX8510	NYG8510	3	B	1.00	2.50	4.00	1.50	2.50	8.50	–	–
	12.00	NSX8512	NYG8512	4	C	1.00	–	4.00	1.50	2.50	–	9.50	10.50
6	4.00	NSX8604	NYG8604	3	B	1.00	3.00	5.00	1.25	2.25	2.75	–	–
	5.00	NSX8605	NYG8605	2	A	1.12	–	4.88	1.50	3.75	–	–	–
	6.00	NSX8606	NYG8606	4	C	1.00	–	5.00	1.25	2.25	–	3.75	4.75
	8.00	NSX8608	NYG8608	4	C	1.00	–	5.00	1.25	2.25	–	5.75	6.75
	10.00	NSX8610	NYG8610	5	D	1.00	3.00	5.00	1.25	2.25	5.00	7.75	8.75
	12.00	NSX8612	NYG8612	5	D	1.00	3.00	5.00	1.25	2.25	6.00	9.75	10.75
8	5.00	NSX8805	NYG8805	2	A	1.25	–	6.75	1.50	3.75	–	–	–
	6.00	NSX8806	NYG8806	4	C	1.00	–	7.00	1.25	2.25	–	3.75	4.75

# NAAMS Series W01, W02 & W03

## Standard & Self-Lubricating Wear Plates – Metric



### Product Features

The NAAMS Series of wear plate fully meets the North American Automotive Standard. They are 20mm thick and available in plain steel, steel with graphite plugs and aluminum-bronze with graphite plugs. The aluminum-bronze and steel with graphite plugs are self-lubricating products and do not require lubrication during production. All NAAMS wear plates are supplied with mounting holes to accommodate M12 S.H.C.S. For ease of identification, all products are marked with the part number.

Steel Without Graphite Plugs		Steel With Graphite Plugs		Alum. Bronze With Graphite Plugs		Width W (mm)	Length L (mm)
Part Number	NAAMS Code #	Part Number	NAAMS Code #	Part Number	NAAMS Code #		
WSX20-50-100	W 025010	WSG20-50-100	W 015010	WYG20-50-100	W 035010	50	100
WSX20-50-150	W 025015	WSG20-50-150	W 015015	WYG20-50-150	W 035015		150
WSX20-50-200	W 025020	WSG20-50-200	W 015020	WYG20-50-200	W 035020		200
WSX20-80-100	W 028010	WSG20-80-100	W 018010	WYG20-80-100	W 038010	80	100
WSX20-80-150	W 028015	WSG20-80-150	W 018015	WYG20-80-150	W 038015		150
WSX20-80-200	W 028020	WSG20-80-200	W 018020	WYG20-80-200	W 038020		200
WSX20-80-250	W 028025	WSG20-80-250	W 018025	WYG20-80-250	W 038025		250
WSX20-80-315	W 028031	WSG20-80-315	W 018031	WYG20-80-315	W 038031	100	315
WSX20-100-50	W 021050	WSG20-100-50	W 011050	WYG20-100-50	W 031050		50
WSX20-100-80	W 021080	WSG20-100-80	W 011080	WYG20-100-80	W 031080		80
WSX20-100-100	W 021010	WSG20-100-100	W 011010	WYG20-100-100	W 031010		100
WSX20-100-150	W 021015	WSG20-100-150	W 011015	WYG20-100-150	W 031015		150
WSX20-100-200	W 021020	WSG20-100-200	W 011020	WYG20-100-200	W 031020		200
WSX20-100-250	W 021025	WSG20-100-250	W 011025	WYG20-100-250	W 031025		250
WSX20-100-315	W 021031	WSG20-100-315	W 011031	WYG20-100-315	W 031031	315	
WSX20-125-80	W 021280	WSG20-125-80	W 011280	WYG20-125-80	W 031280	125	80
WSX20-125-100	W 021210	WSG20-125-100	W 011210	WYG20-125-100	W 031210		100
WSX20-125-150	W 021215	WSG20-125-150	W 011215	WYG20-125-150	W 031215		150
WSX20-125-200	W 021220	WSG20-125-200	W 011220	WYG20-125-200	W 031220		200
WSX20-125-250	W 021225	WSG20-125-250	W 011225	WYG20-125-250	W 031225		250
WSX20-125-315	W 021231	WSG20-125-315	W 011231	WYG20-125-315	W 031231		315
WSX20-160-100	W 021610	WSG20-160-100	W 011610	WYG20-160-100	W 031610	160	100
WSX20-160-150	W 021615	WSG20-160-150	W 011615	WYG20-160-150	W 031615		150
WSX20-160-200	W 021620	WSG20-160-200	W 011620	WYG20-160-200	W 031620		200
WSX20-160-250	W 021625	WSG20-160-250	W 011625	WYG20-160-250	W 031625		250
WSX20-160-315	W 021631	WSG20-160-315	W 011631	WYG20-160-315	W 031631		315



# NAAMS Series W01, W02 & W03 Standard & Self-Lubricating Wear Plates – Metric

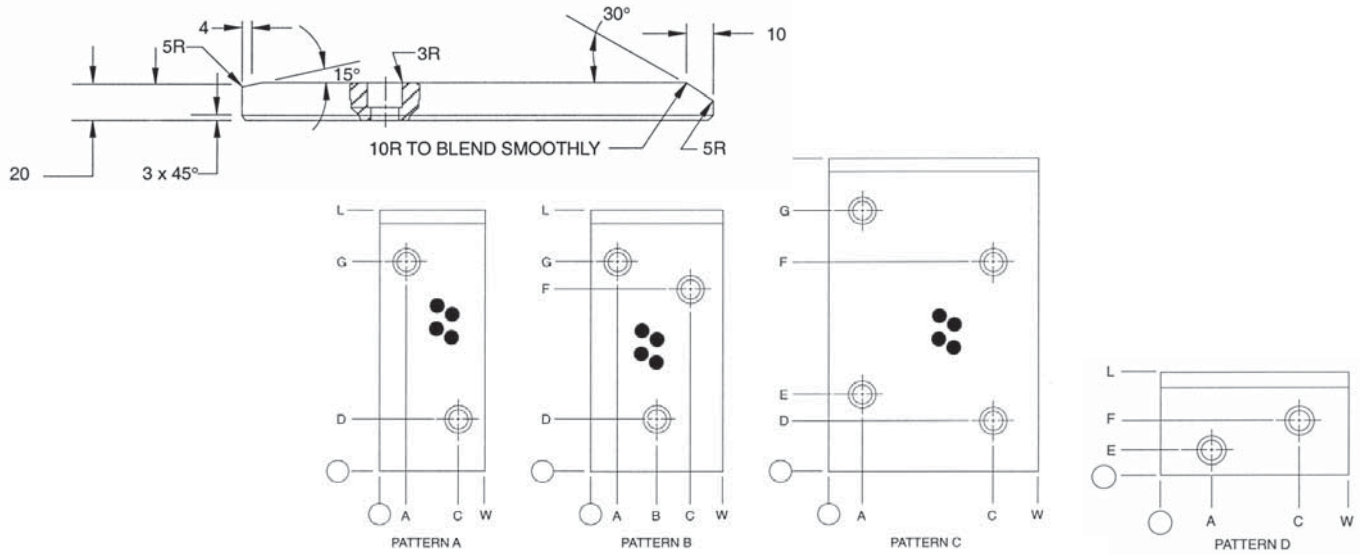

Width W (mm)	Length L (mm)	Mounting Hole Pattern & Location								
		Hole Qty.	Pattern	A (mm)	B (mm)	C (mm)	D (mm)	E (mm)	F (mm)	G (mm)
50	100	2	A	25	-	25	30	-	-	60
	150	2	A		-		30	-	-	110
	200	2	A		-		40	-	-	160
80	100	2	A	20	-	60	30	-	-	60
	150	2	A		-		30	-	-	110
	200	2	A		-		40	-	-	160
	250	2	A		-		40	-	-	210
	315	3	B		40		40	-	250	275
100	50	2	D	22	-	78	-	14	27	-
	80	2	D		-		-	30	50	-
	100	2	A		-		30	-	-	60
	150	2	A		-		30	-	-	110
	200	3	B		50		40	-	135	160
	250	3	B		50		40	-	185	210
	315	3	B		50		40	-	250	275
125	80	2	D	25	-	100	-	30	50	-
	100	2	A		-		30	-	-	60
	150	2	A		-		30	-	-	110
	200	3	B		62		40	-	135	160
	250	3	B		62		40	-	185	210
	315	4	C		-		40	65	250	275
160	100	2	A	30	-	130	30	-	-	60
	150	2	A		-		30	-	-	110
	200	3	B		80		40	-	135	160
	250	4	C		-		40	65	185	210
	315	4	C		-		40	65	250	275

## MATERIALS:

- ◆ Steel wear plates are manufactured from high quality carburized steel. They are precision ground and hardened to Rc 56-60 (1.2 mm to 1.5 mm deep). They are available with or without graphite plugs.
- ◆ Bronze wear plates are manufactured from aluminum bronze material with oil impregnated graphite plugs.
- ◆ When ordered with graphite plugs, the plugs cover 25-30% of the wear surface and are arranged to generate optimal coverage at any engagement direction of the wear plate.

## TOLERANCES:

- ◆ Thickness  $\pm 0.025$  mm
- ◆ Mounting hole locations  $\pm 0.25$  mm
- ◆ Flatness  $\pm 0.012$  mm
- ◆ Unless otherwise noted  $\pm 0.25$  mm

## MOUNTING SCREWS:

- ◆ M12 S.H.C.S. recommended. Plate has 13.5mm through hole with 20mm counterbore 13mm deep.

# JIS Series Standard & Self-Lubricating Wear Plates – Metric



BYG20-58-75

## Product Features

The JIS Series of wear plate fully meets the Japanese Industrial Standard. They are 20mm thick and available in plain steel, steel with graphite plugs and aluminum-bronze with graphite plugs. The aluminum-bronze and steel with graphite plugs are self-lubricating products and do not require lubrication during production. They are supplied with two or four mounting holes to accommodate M10 S.H.C.S. For ease of identification, all products are marked with the part number.

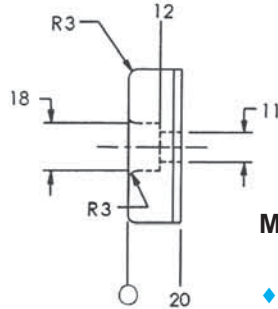
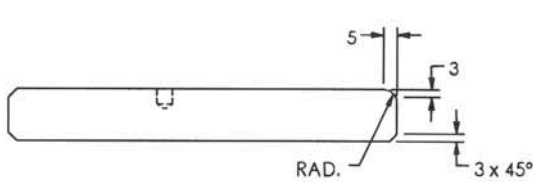

### MATERIALS:

- ◆ Steel wear plates are manufactured from high quality carburized steel. They are precision ground and hardened to Rc 56-60 (1.2 mm to 1.5 mm deep). They are available with or without graphite plugs.
- ◆ Bronze wear plates are manufactured from aluminum bronze material with oil impregnated graphite plugs.
- ◆ When ordered with graphite plugs, the plugs cover 25-30% of the wear surface and are arranged to generate optimal coverage at any engagement direction of the wear plate.

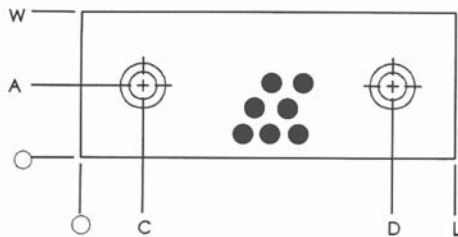

PATTERN A

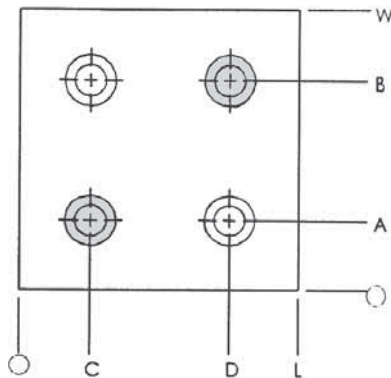

PATTERN B

### TOLERANCES:

- ◆ Thickness  $\pm 0.025$  mm
- ◆ Mounting hole locations  $\pm 0.25$  mm
- ◆ Flatness  $\pm 0.013$  mm
- ◆ Unless otherwise noted  $\pm 0.25$  mm

### MOUNTING SCREWS:

- ◆ M10 S.H.C.S. recommended. Plate has 11mm through hole with 18mm counter-bore 12mm deep.

# JIS Series Standard & Self-Lubricating Wear Plates – Metric

Width W (mm)	Length L (mm)	Steel Part # Without Graphite Plugs	Steel Part # With Graphite Plugs	Alum. Bronze Part # With Graphite Plugs	Hole Qty.	Hole Pattern	A (mm)	B (mm)	C (mm)	D (mm)
28	75	BSX20-28-75	BSG20-28-75	BYG20-28-75	2	A	14.0	-	15.0	60.0
	100	BSX20-28-100	BSG20-28-100	BYG20-28-100					25.0	75.0
	150	BSX20-28-150	BSG20-28-150	BYG20-28-150					25.0	125.0
38	75	BSX20-38-75	BSG20-38-75	BYG20-38-75	2	A	19.0	-	15.0	60.0
	100	BSX20-38-100	BSG20-38-100	BYG20-38-100					25.0	75.0
	150	BSX20-38-150	BSG20-38-150	BYG20-38-150					25.0	125.0
48	75	BSX20-48-75	BSG20-48-75	BYG20-48-75	2	A	24.0	-	15.0	60.0
	100	BSX20-48-100	BSG20-48-100	BYG20-48-100					25.0	75.0
	125	BSX20-48-125	BSG20-48-125	BYG20-48-125					25.0	100.0
	150	BSX20-48-150	BSG20-48-150	BYG20-48-150					25.0	125.0
58	75	BSX20-58-75	BSG20-58-75	BYG20-58-75	2	A	29.0	-	15.0	60.0
	100	BSX20-58-100	BSG20-58-100	BYG20-58-100					25.0	75.0
	150	BSX20-58-150	BSG20-58-150	BYG20-58-150					25.0	125.0
75	75	BSX20-75-75	BSG20-75-75	BYG20-75-75	2	B	25.0	50.0	25.0	50.0
	100	BSX20-75-100	BSG20-75-100	BYG20-75-100	DIAGONAL				25.0	75.0
	125	BSX20-75-125	BSG20-75-125	BYG20-75-125	2	A	37.5	-	25.0	100.0
	150	BSX20-75-150	BSG20-75-150	BYG20-75-150					25.0	125.0
	200	BSX20-75-200	BSG20-75-200	BYG20-75-200					25.0	175.0
100	100	BSX20-100-100	BSG20-100-100	BYG20-100-100	4	B	25.0	75.0	25.0	75.0
	125	BSX20-100-125	BSG20-100-125	BYG20-100-125					25.0	100.0
	150	BSX20-100-150	BSG20-100-150	BYG20-100-150					25.0	125.0
	200	BSX20-100-200	BSG20-100-200	BYG20-100-200					25.0	175.0
	250	BSX20-100-250	BSG20-100-250	BYG20-100-250					25.0	225.0
125	150	BSX20-125-150	BSG20-125-150	BYG20-125-150	4	B	37.5	87.5	25.0	125.0
	200	BSX20-125-200	BSG20-125-200	BYG20-125-200					25.0	175.0
	250	BSX20-125-250	BSG20-125-250	BYG20-125-250					25.0	225.0
150	150	BSX20-150-150	BSG20-150-150	BYG20-150-150	4	B	25.0	125.0	25.0	125.0
	200	BSX20-150-200	BSG20-150-200	BYG20-150-200					25.0	175.0
	250	BSX20-150-250	BSG20-150-250	BYG20-150-250					25.0	225.0

# NAAMS Series W05, W06 & W07/VDI 3357 Wear Plates – Metric



VYG20-50-200

## Product Features

This wear plate conforms to the NAAMS Series W05, W06, W07 and VDI 3357 standards, up to 200mm. They are 20mm thick and available in aluminum-bronze material with graphite, steel with graphite and plain steel. They are also available in the GM sizes in cast iron with graphite.

## VDI/NAAMS STANDARDS

Width W (mm)	Length L (mm)	Aluminum Bronze w/Graphite Plugs Part Number	Steel w/Graphite Plugs Part Number	Steel Plain Part Number	Mounting Hole Pattern & Location						
					Hole Qty.	Hole Pattern	A (mm)	B (mm)	C (mm)	D (mm)	E (mm)
50	80	VYG20-50-80	VSG20-50-80	VSX20-50-80	2	A-2	25	55	–	25	–
	100	VYG20-50-100	VSG20-50-100	VSX20-50-100	2	A-2	25	75	–	25	–
	125	VYG20-50-125	VSG20-50-125	VSX20-50-125	2	A-2	25	100	–	25	–
	160	VYG20-50-160	VSG20-50-160	VSX20-50-160	2	A-2	25	135	–	25	–
	200	VYG20-50-200	VSG20-50-200	VSX20-50-200	2	A-2	25	175	–	25	–
80	50	VYG20-80-50	VSG20-80-50	VSX20-80-50	2	B-2	25	–	25	–	55
	80	VYG20-80-80	VSG20-80-80	VSX20-80-80	2	A-2	25	55	–	40	–
	100	VYG20-80-100	VSG20-80-100	VSX20-80-100	2	A-2	25	75	–	40	–
	125	VYG20-80-125	VSG20-80-125	VSX20-80-125	2	A-2	25	100	–	40	–
	160	VYG20-80-160	VSG20-80-160	VSX20-80-160	2	A-2	25	135	–	40	–
	200	VYG20-80-200	VSG20-80-200	VSX20-80-200	2	A-2	25	175	–	40	–
	250	VYG20-80-250	VSG20-80-250	VSX20-80-250	2	A-2	40	210	–	40	–
315	VYG20-80-315	VSG20-80-315	VSX20-80-315	2	A-2	40	275	–	40	–	
100	50	VYG20-100-50	VSG20-100-50	VSX20-100-50	2	B-2	25	–	25	–	75
	80	VYG20-100-80	VSG20-100-80	VSX20-100-80	2	B-2	40	–	25	–	75
	100	VYG20-100-100	VSG20-100-100	VSX20-100-100	2	A-2	25	75	–	50	–
	125	VYG20-100-125	VSG20-100-125	VSX20-100-125	2	A-2	25	100	–	50	–
	160	VYG20-100-160	VSG20-100-160	VSX20-100-160	2	A-2	25	135	–	50	–
	200	VYG20-100-200	VSG20-100-200	VSX20-100-200	2	A-2	25	175	–	50	–
	250	VYG20-100-250	VSG20-100-250	VSX20-100-250	2	A-2	40	210	–	50	–
315	VYG20-100-315	VSG20-100-315	VSX20-100-315	2	A-2	40	275	–	50	–	
125	50	VYG20-125-50	VSG20-125-50	VSX20-125-50	2	B-2	25	–	25	–	100
	80	VYG20-125-80	VSG20-125-80	VSX20-125-80	2	B-2	40	–	25	–	
	100	VYG20-125-100	VSG20-125-100	VSX20-125-100	3	B-3	25	75	25	62.5	
	125	VYG20-125-125	VSG20-125-125	VSX20-125-125	3	B-3	25	100	25	62.5	
	160	VYG20-125-160	VSG20-125-160	VSX20-125-160	3	B-3	25	135	25	62.5	
	200	VYG20-125-200	VSG20-125-200	VSX20-125-200	3	B-3	25	175	25	62.5	
	250	VYG20-125-250	VSG20-125-250	VSX20-125-250	3	B-3	40	210	25	62.5	
315	VYG20-125-315	VSG20-125-315	VSX20-125-315	3	B-3	40	275	25	62.5		
160	50	VYG20-160-50	VSG20-160-50	VSX20-160-50	2	B-2	25	–	25	–	135
	80	VYG20-160-80	VSG20-160-80	VSX20-160-80	2	B-2	40	–	25	–	
	100	VYG20-160-100	VSG20-160-100	VSX20-160-100	3	B-3	25	75	25	80	
	125	VYG20-160-125	VSG20-160-125	VSX20-160-125	3	B-3	25	100	25	80	
	160	VYG20-160-160	VSG20-160-160	VSX20-160-160	3	B-3	25	135	25	80	
	200	VYG20-160-200	VSG20-160-200	VSX20-160-200	3	B-3	25	175	25	80	
	250	VYG20-160-250	VSG20-160-250	VSX20-160-250	4	C-4	40	210	25	–	
	315	VYG20-160-315	VSG20-160-315	VSX20-160-315	4	C-4	40	275	25	–	

# NAAMS Series W05, W06 & W07/VDI 3357 Wear Plates – Metric

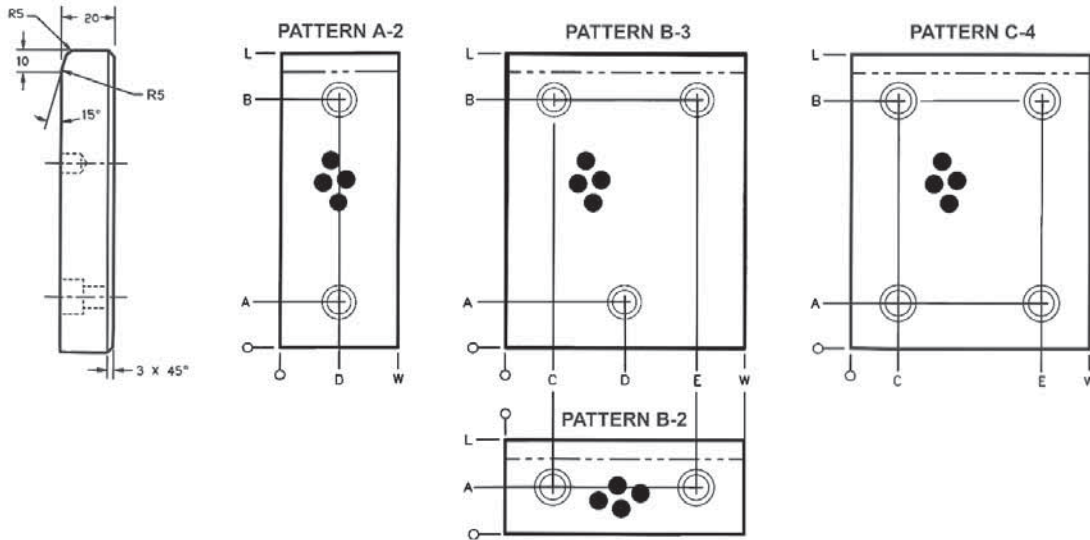

## MATERIALS:

- ◆ Self-lubricating wear plates are manufactured from aluminum bronze or steel with graphite plugs. The plugs cover 20-25% of the wear surface.
- ◆ Wear plates are also available in plain steel.
- ◆ Wear plates are also available in the GM sizes in cast iron with graphite. See the cross reference sheet on pg. 11 for the GM part number.

## TOLERANCES:

- ◆ Thickness  $\pm 0.00/ -0.02$  mm
- ◆ Mounting hole locations  $\pm 0.2$  mm
- ◆ Flatness  $\pm 0.013$  mm
- ◆ Unless otherwise noted  $\pm 0.25$  mm

## MOUNTING SCREWS:

- ◆ M8 S.H.C.S. for part numbers VYG20-50-80 and VYG20-80-50.
- ◆ M12 S.H.C.S. for all other part numbers.

## ADDITIONAL AUTOMOTIVE STANDARDS

Width W (mm)	Length L (mm)	Aluminum Bronze w/Graphite Plugs Part Number	Steel w/Graphite Plugs Part Number	Steel Plain Part Number	Mounting Hole Pattern & Location						
					Hole Qty.	Hole Pattern	A (mm)	B (mm)	C (mm)	D (mm)	E (mm)
100	250	WDX13-80-03100250Y*	WDX13-80-03100250G*	WDX13-80-03100250X*	2	A-2	25	225	-	50	-
	250	90.20.65-100250Y*	-	90.20.65-100250X*	4	C-4	25	225	25	-	75
	315	WDX13-80-03100315Y*	WDX13-80-03100315G*	WDX13-80-03100315X*	2	A-2	25	290	-	50	-
125	200	90.20.65-125200*	-	90.20.65-125200*	4	C-4	25	175	25	-	100
	250	WDX13-80-03125250Y*	WDX13-80-03125250G*	WDX13-80-03125250X*	3	B-3	25	225	25	62.5	100
	250	90.20.65-125250Y*	-	90.20.65-125250X*	4	C-4	25	225	25	-	100
	315	WDX13-80-03125315Y*	WDX13-80-03125315G*	WDX13-80-03125315X*	3	B-3	25	290	25	62.5	100
160	200	90.20.65-160200Y*	-	90.20.65-160200G*	4	C-4	25	175	25	-	135
	250	WDX13-80-03160250Y*	WDX13-80-03160250G*	WDX13-80-03160250X*	3	B-3	25	225	25	80	135
	250	90.20.65-160250Y*	-	90.20.65-160250X*	4	C-4	25	225	25	-	135
	300	90.20.65-160300Y*	-	90.20.65-160300X*	4	C-4	25	275	25	-	135
200	200	90.20.65-200200Y*	-	90.20.65-200200X*	4	C-4	25	175	25	-	175
	250	90.20.65-200250Y*	-	90.20.65-200250X*	4	C-4	25	225	25	-	175
	300	90.20.65-200300Y*	-	90.20.65-200300X*	4	C-4	25	275	25	-	175

## PLEASE NOTE:

- ◆ These wear plates have hole patterns that differ from our standard VDI/NAAMS wear plates. They must be ordered using the GM or Ford part number to receive the correct mounting hole locations.

# Automotive Wear Plate Conversions

Dimensions		BRONZE WITH GRAPHITE PLUGS						STEEL WITH GRAPHITE PLUGS					
		Danly IEM Part Number	NAAMS W07 Series Number	Chrysler Part Number	Ford Part Number	General Motors Part Number	Danly IEM Part Number	NAAMS W05 Series Number	Ford Part Number	Width	Length		
50	80	VYG20-50-80					VSG20-50-80						
50	100	VYG20-50-100	W070510	19-290-3204	WDX13803050100Y	90.20.65-50100Y	VSG20-50-100	W050510	WDX13803050100G				
50	125	VYG20-50-125	W070512	19-290-3205	WDX13803050125Y	90.20.65-50125Y	VSG20-50-125	W050512	WDX13803050125G				
50	160	VYG20-50-160	W070516	19-290-3206	WDX13803050160Y	90.20.65-50160Y	VSG20-50-160	W050516	WDX13803050160G				
50	200	VYG20-50-200	W070520	19-290-3208	WDX13803050200Y	90.20.65-50200Y	VSG20-50-200	W050520	WDX13803050200G				
80	50	VYG20-80-50					VSG20-80-50						
80	80	VYG20-80-80					VSG20-80-80						
80	100	VYG20-80-100	W070810	19-290-3304	WDX13803080100Y	90.20.65-80100Y	VSG20-80-100	W050810	WDX13803080100G				
80	125	VYG20-80-125	W070812	19-290-3305	WDX13803080125Y	90.20.65-80125Y	VSG20-80-125	W050812	WDX13803080125G				
80	160	VYG20-80-160	W070816	19-290-3306	WDX13803080160Y	90.20.65-80160Y	VSG20-80-160	W050816	WDX13803080160G				
80	200	VYG20-80-200	W070820	19-290-3308	WDX13803080200Y	90.20.65-80200Y	VSG20-80-200	W050820	WDX13803080200G				
80	250	VYG20-80-250		19-290-3310			VSG20-80-250						
80	315	VYG20-80-315		19-290-3312			VSG20-80-315						
100	50	VYG20-100-50		19-290-3402			VSG20-100-50						
100	80	VYG20-100-80	W071080	19-290-3403	WDX13803100080Y	90.20.65-10080Y	VSG20-100-80	W051080	WDX13803100080G				
100	100	VYG20-100-100	W071010	19-290-3404	WDX13803100100Y	90.20.65-100100Y	VSG20-100-100	W051010	WDX13803100100G				
100	125	VYG20-100-125	W071012	19-290-3405	WDX13803100125Y	90.20.65-100125Y	VSG20-100-125	W051012	WDX13803100125G				
100	160	VYG20-100-160	W071016	19-290-3406	WDX13803100160Y	90.20.65-100160Y	VSG20-100-160	W051016	WDX13803100160G				
100	200	VYG20-100-200	W071020	19-290-3408	WDX13803100200Y	90.20.65-100200Y	VSG20-100-200	W051020	WDX13803100200G				
100	250	VYG20-100-250		19-290-3410	WDX13803100250Y	90.20.65-100250Y	VSG20-100-250		WDX13803100250G				
100	315	VYG20-100-315		19-290-3412	WDX13803100315Y		VSG20-100-315		WDX13803100315G				
125	50	VYG20-125-50					VSG20-125-50						
125	80	VYG20-125-80	W071208	19-290-3503	WDX13803125080Y	90.20.65-125080Y	VSG20-125-80	W051208	WDX13803125080G				
125	100	VYG20-125-100	W071210	19-290-3504	WDX13803125100Y	90.20.65-125100Y	VSG20-125-100	W051210	WDX13803125100G				
125	125	VYG20-125-125	W071212	19-290-3505	WDX13803125125Y	90.20.65-125125Y	VSG20-125-125	W051212	WDX13803125125G				
125	160	VYG20-125-160	W071216	19-290-3506	WDX13803125160Y	90.20.65-125160Y	VSG20-125-160	W051216	WDX13803125160G				
125	200	VYG20-125-200	W071220	19-290-3508	WDX13803125200Y	90.20.65-125200Y	VSG20-125-200	W051220	WDX13803125200G				
125	250	VYG20-125-250		19-290-3510	WDX13803125250Y	90.20.65-125250Y	VSG20-125-250		WDX13803125250G				
125	315	VYG20-125-315		19-290-3512	WDX13803125315Y		VSG20-125-315		WDX13803125315G				
160	50	VYG20-160-50					VSG20-160-50						
160	80	VYG20-160-80					VSG20-160-80						
160	100	VYG20-160-100	W071610	19-290-3604	WDX13803160100Y	90.20.65-160100Y	VSG20-160-100	W051610	WDX13803160100G				
160	125	VYG20-160-125	W071612	19-290-3605	WDX13803160125Y	90.20.65-160125Y	VSG20-160-125	W051612	WDX13803160125G				
160	160	VYG20-160-160	W071616	19-290-3606	WDX13803160160Y	90.20.65-160160Y	VSG20-160-160	W051616	WDX13803160160G				
160	200	VYG20-160-200	W071620	19-290-3608	WDX13803160200Y	90.20.65-160200Y	VSG20-160-200		WDX13803160200G				
160	250	VYG20-160-250		19-290-3610	WDX13803160250Y	90.20.65-160250Y	VSG20-160-250		WDX13803160250G				
160	300												
160	315	VYG20-160-315		19-290-3612	WDX13803160315Y		VSG20-160-315		WDX13803160315G				
200	200												
200	250												
200	300												

**PLEASE NOTE:**

- ◆ The highlighted items (in grey) have different hole patterns than our existing wear plates. They do not convert to an IEM part number and must be ordered as highlighted.



# Automotive Wear Plate Conversions

Dimensions		PLAIN STEEL						CAST IRON w/GRAPHITE PLUGS	
Width	Length	Daily IEM Part Number	NAAAMS W06 Series Number	Chrysler Part Number	Ford Part Number Part Number	General Motors Part Number	General Motors Part Number	General Motors Part Number	
50	80	VSX20-50-80							
50	100	VSX20-50-100	W060510	19-290-4204	WDX13803050100X	90.20.65-50100X	90.20.65-50100C		
50	125	VSX20-50-125	W060512	19-290-4205	WDX13803050125X	90.20.65-50125X	90.20.65-50125C		
50	160	VSX20-50-160	W060516	19-290-4206	WDX13803050160X	90.20.65-50160X	90.20.65-50160C		
50	200	VSX20-50-200	W060520	19-290-4208	WDX13803050200X	90.20.65-50200X	90.20.65-50200C		
80	50	VSX20-80-50							
80	80	VSX20-80-80							
80	100	VSX20-80-100	W060810	19-290-4304	WDX13803080100X	90.20.65-80100X	90.20.65-80100C		
80	125	VSX20-80-125	W060812	19-290-4305	WDX13803080125X	90.20.65-80125X	90.20.65-80125C		
80	160	VSX20-80-160	W060816	19-290-4306	WDX13803080160X	90.20.65-80160X	90.20.65-80160C		
80	200	VSX20-80-200	W060820	19-290-4308	WDX13803080200X	90.20.65-80200X	90.20.65-80200C		
80	250	VSX20-80-250		19-290-4310					
80	315	VSX20-80-315		19-290-4312					
100	50	VSX20-100-50		19-290-4402		90.20.65-10050X	90.20.65-10050C		
100	80	VSX20-100-80	W061080	19-290-4403	WDX13803100080X	90.20.65-10080X	90.20.65-10080C		
100	100	VSX20-100-100	W061010	19-290-4404	WDX13803100100X	90.20.65-100100X	90.20.65-100100C		
100	125	VSX20-100-125	W061012	19-290-4405	WDX13803100125X	90.20.65-100125X	90.20.65-100125C		
100	160	VSX20-100-160	W061016	19-290-4406	WDX13803100160X	90.20.65-100160X	90.20.65-100160C		
100	200	VSX20-100-200	W061020	19-290-4408	WDX13803100200X	90.20.65-100200X	90.20.65-100200C		
100	250	VSX20-100-250		19-290-4410	WDX13803100250X	90.20.65-100250X	90.20.65-100250C		
100	315	VSX20-100-315		19-290-4412	WDX13803100315X				
125	50	VSX20-125-50							
125	80	VSX20-125-80	W061208	19-290-4503	WDX13803125080X	90.20.65-12580X	90.20.65-12580C		
125	100	VSX20-125-100	W061210	19-290-4504	WDX13803125100X	90.20.65-125100X	90.20.65-125100C		
125	125	VSX20-125-125	W061212	19-290-4505	WDX13803125125X	90.20.65-125125X	90.20.65-125125C		
125	160	VSX20-125-160	W061216	19-290-4506	WDX13803125160X	90.20.65-125160X	90.20.65-125160C		
125	200	VSX20-125-200	W061220	19-290-4508	WDX13803125200X	90.20.65-125200X	90.20.65-125200C		
125	250	VSX20-125-250		19-290-4510	WDX13803125250X	90.20.65-125250X	90.20.65-125250C		
125	315	VSX20-125-315		19-290-4512	WDX13803125315X				
160	50	VSX20-160-50							
160	80	VSX20-160-80							
160	100	VSX20-160-100	W061610	19-290-4604	WDX13803160100X	90.20.65-160100X	90.20.65-160100C		
160	125	VSX20-160-125	W061612	19-290-4605	WDX13803160125X	90.20.65-160125X	90.20.65-160125C		
160	160	VSX20-160-160	W061616	19-290-4606	WDX13803160160X	90.20.65-160160X	90.20.65-160160C		
160	200	VSX20-160-200	W061620	19-290-4608	WDX13803160200X	90.20.65-160200X	90.20.65-160200C		
160	250	VSX20-160-250		19-290-4610	WDX13803160250X	90.20.65-160250X	90.20.65-160250C		
160	300					90.20.65-160300X	90.20.65-160300C		
160	315	VSX20-160-315		19-290-4612	WDX13803160315X				
200	200					90.20.65-200200X	90.20.65-200200C		
200	250					90.20.65-200250X	90.20.65-200250C		
200	300					90.20.65-200300X	90.20.65-200300C		

**PLEASE NOTE:**

- ◆ The highlighted items (in grey) have different hole patterns than our existing wear plates. They do not convert to an IEM part number and must be ordered as highlighted.
- ◆ Cast iron must be ordered using the GM part number.

# Plain Bronze & Self-Lubricating Wearstrips – Inch

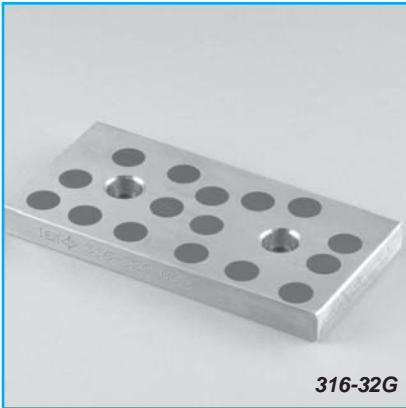

## Product Features

This Inch Series of wearstrip is available in 1/4", 3/8", 1/2" and 5/8" thicknesses and is manufactured in aluminum-bronze material with or without graphite plugs. They are supplied with 2 to 8 mounting holes dependant on the width and length of the strip. For ease of identification, all products are marked with the part number.

PATTERN A

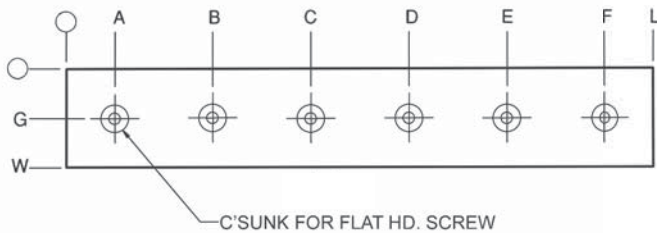

PATTERN B

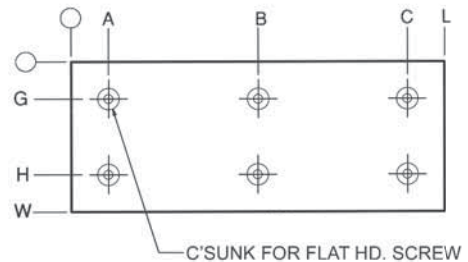

PATTERN C

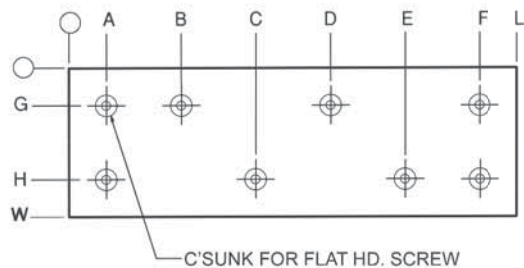

### MATERIALS:

- ◆ Aluminum bronze material with or without oil-impregnated graphite plugs. When ordered with graphite plugs, the plugs cover 25-30% of the wear surface and are arranged to generate optimal coverage at any engagement direction of the wear plate.

### TOLERANCES:

- ◆ Thickness  $\pm 0.001$  in.
- ◆ Mounting hole locations  $\pm 0.010$  in.
- ◆ Unless otherwise noted  $\pm 0.010$  in.

### MOUNTING SCREWS:

- ◆ 1/4" thick plates: 1/4" flat head screw recommended
- ◆ 3/8" thick plates: 1/4" S.H.C.S. recommended
- ◆ 1/2" thick plates: 5/16" S.H.C.S. recommended
- ◆ 5/8" thick plates: 5/16" S.H.C.S. recommended

# Plain Bronze & Self-Lubricating Wearstrips – Inch

Width W	Length L	Mounting Hole Pattern & Location									
		Hole Qty.	Hole Pattern	A (in)	B (in)	C (in)	D (in)	E (in)	F (in)	G (in)	H (in)
1.00	4.00	2	A	1.00	3.00	–	–	–	–	0.50	–
	5.00	3		.50	2.50	4.50	–	–	–	0.50	
	6.00	3		1.00	3.00	5.00	–	–	–	0.50	
	8.00	4		1.00	3.00	5.00	7.00	–	–	0.50	
	10.00	5		1.00	3.00	5.00	7.00	9.00	–	0.50	
	12.00	6		1.00	3.00	5.00	7.00	9.00	11.00	0.50	
1.50	3.00	2	A	.50	2.50	–	–	–	–	0.75	–
	4.00	2		1.00	3.00	–	–	–	–	0.75	
	5.00	3		.50	2.50	4.50	–	–	–	0.75	
	6.00	3		1.00	3.00	5.00	–	–	–	0.75	
	8.00	4		1.00	3.00	5.00	7.00	–	–	0.75	
	10.00	5		1.00	3.00	5.00	7.00	9.00	–	0.75	
	12.00	6		1.00	3.00	5.00	7.00	9.00	11.00	0.75	
2.00	3.00	2	A	.50	2.50	–	–	–	–	1.00	–
	4.00	2		1.00	3.00	–	–	–	–	1.00	
	5.00	3		.50	2.50	4.50	–	–	–	1.00	
	6.00	3		1.00	3.00	5.00	–	–	–	1.00	
	8.00	4		1.00	3.00	5.00	7.00	–	–	1.00	
	10.00	5		1.00	3.00	5.00	7.00	9.00	–	1.00	
	12.00	6		1.00	3.00	5.00	7.00	9.00	11.00	1.00	
2.50	3.00	2	A	.50	2.50	–	–	–	–	1.25	–
	4.00	2		1.00	3.00	–	–	–	–	1.25	
	5.00	3		.50	2.50	4.50	–	–	–	1.25	
	6.00	3		1.00	3.00	5.00	–	–	–	1.25	
	8.00	4		1.00	3.00	5.00	7.00	–	–	1.25	
	10.00	5		1.00	3.00	5.00	7.00	9.00	–	1.25	
	12.00	6		1.00	3.00	5.00	7.00	9.00	11.00	1.25	
3.00	3.00	4	B	.50	2.50	–	–	–	–	0.50	2.50
	4.00	4	B	1.00	3.00	–	–	–	–	0.50	
	5.00	4	B	.50	4.50	–	–	–	–	0.50	
	6.00	4	B	1.00	5.00	–	–	–	–	0.50	
	8.00	6	C	1.00	3.00	5.00	–	–	7.00	0.50	
	10.00	6	B	1.00	5.00	9.00	–	–	–	0.50	
	12.00	8	C	1.00	3.00	5.00	7.00	9.00	11.00	0.50	
4.00	4.00	4	B	1.00	3.00	–	–	–	–	1.00	3.00
	5.00	4	B	.50	4.50	–	–	–	–	1.00	
	6.00	4	B	1.00	5.00	–	–	–	–	1.00	
	8.00	6	C	1.00	3.00	5.00	–	–	7.00	1.00	
	10.00	6	B	1.00	5.00	9.00	–	–	–	1.00	
	12.00	8	C	1.00	3.00	5.00	7.00	9.00	11.00	1.00	

**NOTE:** See page 14 for part number and ordering information.

# Plain Bronze & Self-Lubricating Wearstrips – Inch

	Width W (in)	Length L (in)	With Graphite Plugs Part #	Without Graphite Plugs Part #
<b>1/4" Thick Wear Strips</b>	1.00	4.00	28-32G	28-32
		5.00	28-40G	28-40
		6.00	28-48G	28-48
		8.00	28-64G	28-64
		10.00	28-80G	28-80
		12.00	28-96G	28-96
	1.50	4.00	212-32G	212-32
		5.00	212-40G	212-40
		6.00	212-48G	212-48
		8.00	212-64G	212-64
		10.00	212-80G	212-80
		12.00	212-96G	212-96
	2.00	4.00	216-32G	216-32
		5.00	216-40G	216-40
		6.00	216-48G	216-48
		8.00	216-64G	216-64
		10.00	216-80G	216-80
		12.00	216-96G	216-96
	2.50	4.00	220-32G	220-32
		5.00	220-40G	220-40
		6.00	220-48G	220-48
		8.00	220-64G	220-64
		10.00	220-80G	220-80
		12.00	220-96G	220-96
3.00	4.00	224-32G	224-32	
	5.00	224-40G	224-40	
	6.00	224-48G	224-48	
	8.00	224-64G	224-64	
	10.00	224-80G	224-80	
	12.00	224-96G	224-96	
4.00	4.00	232-32G	232-32	
	5.00	232-40G	232-40	
	6.00	232-48G	232-48	
	8.00	232-64G	232-64	
	10.00	232-80G	232-80	
	12.00	232-96G	232-96	
<b>1/2" Thick Wear Strips</b>	1.50	3.00	412-24G	412-24
		4.00	412-32G	412-32
		5.00	412-40G	412-40
		6.00	412-48G	412-48
		8.00	412-64G	412-64
		10.00	412-80G	412-80
	2.00	3.00	416-24G	416-24
		4.00	416-32G	416-32
		5.00	416-40G	416-40
		6.00	416-48G	416-48
		8.00	416-64G	416-64
		10.00	416-80G	416-80
	2.50	3.00	420-24G	420-24
		4.00	420-32G	420-32
		5.00	420-40G	420-40
		6.00	420-48G	420-48
		8.00	420-64G	420-64
		10.00	420-80G	420-80
	3.00	3.00	424-24G	424-24
		4.00	424-32G	424-32
		5.00	424-40G	424-40
		6.00	424-48G	424-48
		8.00	424-64G	424-64
		10.00	424-80G	424-80
4.00	4.00	432-32G	432-32	
	5.00	432-40G	432-40	
	6.00	432-48G	432-48	
	8.00	432-64G	432-64	
	10.00	432-80G	432-80	
	12.00	432-96G	432-96	

	Width W (in)	Length L (in)	With Graphite Plugs Part #	Without Graphite Plugs Part #
<b>3/8" Thick Wear Strips</b>	1.00	4.00	38-32G	38-32
		5.00	38-40G	38-40
		6.00	38-48G	38-48
		8.00	38-64G	38-64
		10.00	38-80G	38-80
		12.00	38-96G	38-96
	1.50	4.00	312-32G	312-32
		5.00	312-40G	312-40
		6.00	312-48G	312-48
		8.00	312-64G	312-64
		10.00	312-80G	312-80
		12.00	312-96G	312-96
	2.00	4.00	316-32G	316-32
		5.00	316-40G	316-40
		6.00	316-48G	316-48
		8.00	316-64G	316-64
		10.00	316-80G	316-80
		12.00	316-96G	316-96
	2.50	4.00	320-32G	320-32
		5.00	320-40G	320-40
		6.00	320-48G	320-48
		8.00	320-64G	320-64
		10.00	320-80G	320-80
		12.00	320-96G	320-96
3.00	4.00	324-32G	324-32	
	5.00	324-40G	324-40	
	6.00	324-48G	324-48	
	8.00	324-64G	324-64	
	10.00	324-80G	324-80	
	12.00	324-96G	324-96	
4.00	4.00	332-32G	332-32	
	5.00	332-40G	332-40	
	6.00	332-48G	332-48	
	8.00	332-64G	332-64	
	10.00	332-80G	332-80	
	12.00	332-96G	332-96	
<b>5/8" Thick Wear Strips</b>	1.50	3.00	512-24G	512-24
		4.00	512-32G	512-32
		5.00	512-40G	512-40
		6.00	512-48G	512-48
		8.00	512-64G	512-64
		10.00	512-80G	512-80
	2.00	3.00	516-24G	516-24
		4.00	516-32G	516-32
		5.00	516-40G	516-40
		6.00	516-48G	516-48
		8.00	516-64G	516-64
		10.00	516-80G	516-80
	2.50	3.00	520-24G	520-24
		4.00	520-32G	520-32
		5.00	520-40G	520-40
		6.00	520-48G	520-48
		8.00	520-64G	520-64
		10.00	520-80G	520-80
	3.00	3.00	524-24G	524-24
		4.00	524-32G	524-32
		5.00	524-40G	524-40
		6.00	524-48G	524-48
		8.00	524-64G	524-64
		10.00	524-80G	524-80
4.00	4.00	532-32G	532-32	
	5.00	532-40G	532-40	
	6.00	532-48G	532-48	
	8.00	532-64G	532-64	
	10.00	532-80G	532-80	
	12.00	532-96G	532-96	

# Self-Lubricating Wearstrip Ways – Inch

## Product Features

This Inch Series of wearstrips is sold in 40-inch lengths without mounting holes. They are designed to be cut to length and drilled for mounting as required. They are manufactured from self-lubricated aluminum-bronze material with oil-impregnated graphite plugs. They are available in 3/8", 1/2", 5/8" and 3/4" thicknesses. For ease of identification, all products are marked with the part number.

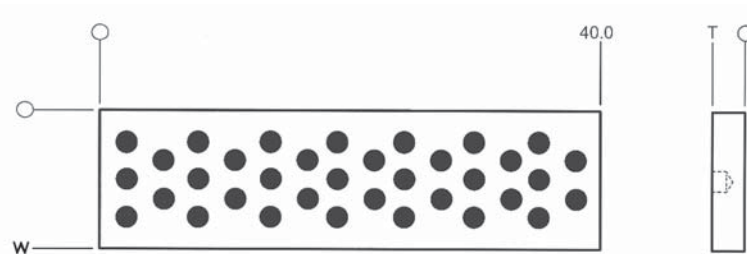
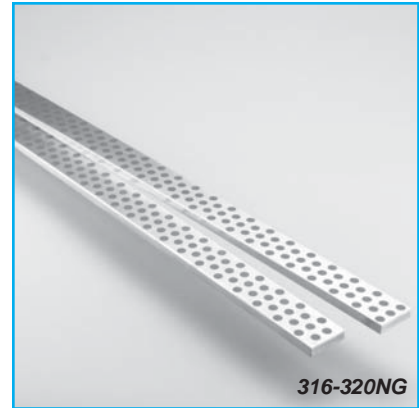

Part Number	Thickness T (in)	Width W (in)	Plug Diameter (in)
312-320NG	0.375	1.50	5/16
316-320NG		2.00	3/8
320-320NG		2.50	3/8
324-320NG		3.00	1/2
412-320NG	0.500	1.50	5/16
416-320NG		2.00	3/8
420-320NG		2.50	3/8
424-320NG		3.00	1/2
432-320NG		4.00	1/2
516-320NG	0.625	2.00	3/8
524-320NG		3.00	1/2
532-320NG		4.00	1/2
616-320NG	0.750	2.00	3/8
624-320NG		3.00	1/2
632-320NG		4.00	1/2
640-320NG		5.00	1/2

### MATERIALS:

- ◆ Aluminum bronze material with oil impregnated graphite plugs. The plugs cover 25-30% of the wear surface and are arranged to generate optimal coverage at any engagement direction of the wearstrip.

### TOLERANCES:

- ◆ Thickness  $\pm 0.001$  in.
- ◆ Unless otherwise noted  $\pm 0.010$  in.

### MOUNTING SCREWS:

- ◆ Normal procedure is to use the graphite plug location for screw hole location.
- ◆ 1/4" flathead or socket head screw (maximum) recommended for 3/8" thick strips.
- ◆ 3/8" flathead or socket head screw (maximum) recommended for 1/2", 5/8" and 3/4" inch thick strips.

# Plain Bronze & Self-Lubricating Wearstrips – Inch



## Product Features

This Inch Series of wearstrip is available in 1/4", 3/8", 1/2" and 5/8" thicknesses and is manufactured in aluminum-bronze material with or without graphite plugs. They are supplied without mounting holes. For ease of identification, all products are marked with the part number.

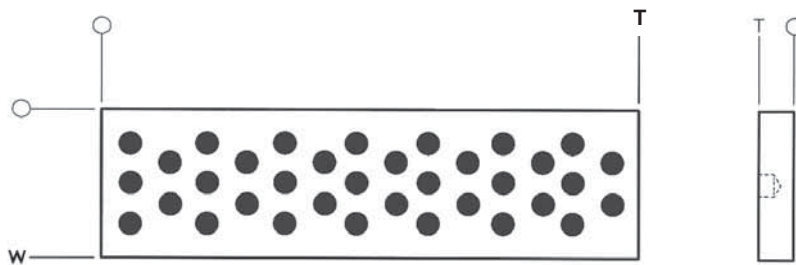

### MATERIALS:

- ◆ Aluminum bronze material with or without oil impregnated graphite plugs. When ordered with graphite plugs, the plugs cover 25-30% of the wear surface and are arranged to generate optimal coverage at any engagement direction of the wearstrip.

### TOLERANCES:

- ◆ Thickness  $\pm 0.001$  in.
- ◆ Unless otherwise noted  $\pm 0.010$  in.

### MOUNTING SCREWS:

- ◆ Mounting holes must be drilled. Recommend using plug locations for drilling mounting holes.



# Plain Bronze & Self-Lubricating Wearstrips – Inch

	Width	Length	With	Without
	W (in)	L (in)	Graphite Plugs Part #	Graphite Plugs Part #
<b>1/4" Thick Wear Strips</b>	1	4	28-32NG	28-32N
		5	28-40NG	28-40N
		6	28-48NG	28-48N
		8	28-64NG	28-64N
		10	28-80NG	28-80N
	1.5	4	212-32NG	212-32N
		5	212-40NG	212-40N
		6	212-48NG	212-48N
		8	212-64NG	212-64N
		10	212-80NG	212-80N
	2	4	216-32NG	216-32N
		5	216-40NG	216-40N
		6	216-48NG	216-48N
		8	216-64NG	216-64N
		10	216-80NG	216-80N
	2.5	4	220-32NG	220-32N
		5	220-40NG	220-40N
		6	220-48NG	220-48N
		8	220-64NG	220-64N
		10	220-80NG	220-80N
	3	4	224-32NG	224-32N
		5	224-40NG	224-40N
		6	224-48NG	224-48N
		8	224-64NG	224-64N
10		224-80NG	224-80N	
4	4	232-32NG	232-32N	
	5	232-40NG	232-40N	
	6	232-48NG	232-48N	
	8	232-64NG	232-64N	
	10	232-80NG	232-80N	
<b>1/2" Thick Wear Strips</b>	1.5	3	412-24NG	412-24N
		4	412-32NG	412-32N
		5	412-40NG	412-40N
		6	412-48NG	412-48N
		8	412-64NG	412-64N
		10	412-80NG	412-80N
	2	3	416-24NG	416-24N
		4	416-32NG	416-32N
		5	416-40NG	416-40N
		6	416-48NG	416-48N
		8	416-64NG	416-64N
		10	416-80NG	416-80N
	2.5	3	420-24NG	420-24N
		4	420-32NG	420-32N
		5	420-40NG	420-40N
		6	420-48NG	420-48N
		8	420-64NG	420-64N
		10	420-80NG	420-80N
	3	3	424-24NG	424-24N
		4	424-32NG	424-32N
		5	424-40NG	424-40N
		6	424-48NG	424-48N
		8	424-64NG	424-64N
		10	424-80NG	424-80N
4	3	424-96NG	424-96N	
	4	432-32NG	432-32N	
	5	432-40NG	432-40N	
	6	432-48NG	432-48N	
	8	432-64NG	432-64N	
	10	432-80NG	432-80N	
12	4	432-96NG	432-96N	
	5	432-96NG	432-96N	
	6	432-96NG	432-96N	
	8	432-96NG	432-96N	
	10	432-96NG	432-96N	
	12	432-96NG	432-96N	

	Width	Length	With	Without
	W (in)	L (in)	Graphite Plugs Part #	Graphite Plugs Part #
<b>3/8" Thick Wear Strips</b>	1	4	38-32NG	38-32N
		5	38-40NG	38-40N
		6	38-48NG	38-48N
		8	38-64NG	38-64N
		10	38-80NG	38-80N
	1.5	4	312-32NG	312-32N
		5	312-40NG	312-40N
		6	312-48NG	312-48N
		8	312-64NG	312-64N
		10	312-80NG	312-80N
	2	4	316-32NG	316-32N
		5	316-40NG	316-40N
		6	316-48NG	316-48N
		8	316-64NG	316-64N
		10	316-80NG	316-80N
	2.5	4	320-32NG	320-32N
		5	320-40NG	320-40N
		6	320-48NG	320-48N
		8	320-64NG	320-64N
		10	320-80NG	320-80N
	3	4	324-32NG	324-32N
		5	324-40NG	324-40N
		6	324-48NG	324-48N
		8	324-64NG	324-64N
10		324-80NG	324-80N	
4	4	324-96NG	324-96N	
	4	332-32NG	332-32N	
	5	332-40NG	332-40N	
	6	332-48NG	332-48N	
	8	332-64NG	332-64N	
<b>5/8" Thick Wear Strips</b>	1.5	3	512-24NG	512-24N
		4	512-32NG	512-32N
		5	512-40NG	512-40N
		6	512-48NG	512-48N
		8	512-64NG	512-64N
		10	512-80NG	512-80N
	2	3	512-96NG	512-96N
		3	516-24NG	516-24N
		4	516-32NG	516-32N
		5	516-40NG	516-40N
		6	516-48NG	516-48N
		8	516-64NG	516-64N
	2.5	10	516-80NG	516-80N
		12	516-96NG	516-96N
		3	520-24NG	520-24N
		4	520-32NG	520-32N
		5	520-40NG	520-40N
		6	520-48NG	520-48N
	3	8	520-64NG	520-64N
		10	520-80NG	520-80N
		12	520-96NG	520-96N
		3	524-24NG	524-24N
		4	524-32NG	524-32N
		5	524-40NG	524-40N
4	6	524-48NG	524-48N	
	8	524-64NG	524-64N	
	10	524-80NG	524-80N	
	12	524-96NG	524-96N	
	4	532-32NG	532-32N	
	5	532-40NG	532-40N	
12	6	532-48NG	532-48N	
	8	532-64NG	532-64N	
	10	532-80NG	532-80N	
	12	532-96NG	532-96N	
	4	532-96NG	532-96N	
	5	532-96NG	532-96N	

# NAAMS Series Self-Lubricating Wearstrips

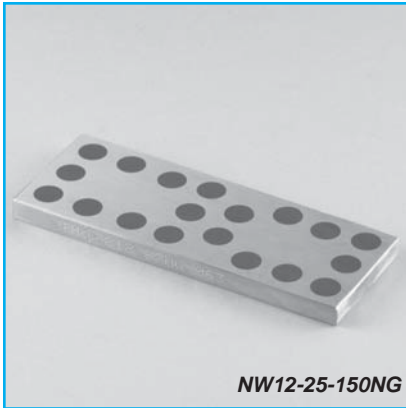

NW12-25-150NG

## Product Features

The NAAMS Series of wearstrip fully meets the North American Automotive Standard. They are manufactured from aluminum-bronze material with oil-impregnated graphite plugs.

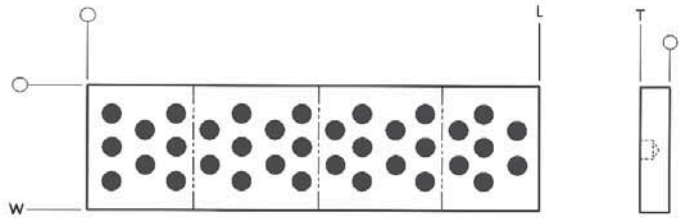

Thkns. T (mm)	Width W (mm)	Length L (mm)	Part Number	NAAMS Code
10	25	150	NW10-25-150NG	W511025
	40		NW10-40-150NG	W511040
	50		NW10-50-150NG	W511050
	63		NW10-63-150NG	W511063
	75		NW10-75-150NG	W511075
	100		NW10-100-150NG	W511010
	125		NW10-125-150NG	W511012
	150		NW10-150-150NG	W511015
12	25	150	NW12-25-150NG	W511225
	40		NW12-40-150NG	W511240
	50		NW12-50-150NG	W511250
	63		NW12-63-150NG	W511263
	75		NW12-75-150NG	W511275
	100		NW12-100-150NG	W511210
	125		NW12-125-150NG	W511212
	150		NW12-150-150NG	W511215
15	25	150	NW15-25-150NG	W511525
	40		NW15-40-150NG	W511540
	50		NW15-50-150NG	W511550
	63		NW15-63-150NG	W511563
	75		NW15-75-150NG	W511575
	100		NW15-100-150NG	W511510
	125		NW15-125-150NG	W511512
	150		NW15-150-150NG	W511515
20	25	150	NW20-25-150NG	W512025
	40		NW20-40-150NG	W512040
	50		NW20-50-150NG	W512050
	63		NW20-63-150NG	W512063
	75		NW20-75-150NG	W512075
	100		NW20-100-150NG	W512010
	125		NW20-125-150NG	W512012
	150		NW20-150-150NG	W512015

Thkns. T (mm)	Width W (mm)	Length L (mm)	Part Number	NAAMS Code
10	25	300	NW10-25-300NG	W531025
	40		NW10-40-300NG	W531040
	50		NW10-50-300NG	W531050
	63		NW10-63-300NG	W531063
	75		NW10-75-300NG	W531075
	100		NW10-100-300NG	W531010
	125		NW10-125-300NG	W531012
	150		NW10-150-300NG	W531015
12	25	300	NW12-25-300NG	W531225
	40		NW12-40-300NG	W531240
	50		NW12-50-300NG	W531250
	63		NW12-63-300NG	W531263
	75		NW12-75-300NG	W531275
	100		NW12-100-300NG	W531210
	125		NW12-125-300NG	W531212
	150		NW12-150-300NG	W531215
15	25	300	NW15-25-300NG	W531525
	40		NW15-40-300NG	W531540
	50		NW15-50-300NG	W531550
	63		NW15-63-300NG	W531563
	75		NW15-75-300NG	W531575
	100		NW15-100-300NG	W531510
	125		NW15-125-300NG	W531512
	150		NW15-150-300NG	W531515
20	25	300	NW20-25-300NG	W532025
	40		NW20-40-300NG	W532040
	50		NW20-50-300NG	W532050
	63		NW20-63-300NG	W532063
	75		NW20-75-300NG	W532075
	100		NW20-100-300NG	W532010
	125		NW20-125-300NG	W532012
	150		NW20-150-300NG	W532015

# NAAMS Series Self-Lubricating Wearstrips

## MATERIALS:

- ◆ Aluminum bronze material with oil-impregnated graphite plugs. The plugs cover 25-30% of the wear surface and are arranged to generate optimal coverage at any engagement direction of the wearstrip.

## TOLERANCES:

- ◆ Thickness  $\pm 0.025$  mm
- ◆ Mounting hole locations  $\pm 0.25$  mm
- ◆ Unless otherwise noted  $\pm 0.25$  mm

## MOUNTING SCREWS:

- ◆ Normal procedure is to use the graphite plug location for screw hole location.
- ◆ M6 flathead or socket head screw (maximum) recommended for 10mm thick plates.
- ◆ M10 flathead or socket head screw (maximum) recommended for 12, 15 and 20mm thick plates.

Thkns. T (mm)	Width W (mm)	Length L (mm)	Part Number	NAAMS Code
10	25	600	NW10-25-600NG	W551025
	40		NW10-40-600NG	W551040
	50		NW10-50-600NG	W551050
	63		NW10-63-600NG	W551063
	75		NW10-75-600NG	W551075
	100		NW10-100-600NG	W551010
	125		NW10-125-600NG	W551012
	150		NW10-150-600NG	W551015
12	25		NW12-25-600NG	W551225
	40		NW12-40-600NG	W551240
	50		NW12-50-600NG	W551250
	63		NW12-63-600NG	W551263
	75		NW12-75-600NG	W551275
	100		NW12-100-600NG	W551210
	125		NW12-125-600NG	W551212
	150		NW12-150-600NG	W551215
15	25		NW15-25-600NG	W551525
	40		NW15-40-600NG	W551540
	50		NW15-50-600NG	W551550
	63		NW15-63-600NG	W551563
	75		NW15-75-600NG	W551575
	100		NW15-100-600NG	W551510
	125		NW15-125-600NG	W551512
	150		NW15-150-600NG	W551515
20	25		NW20-25-600NG	W552025
	40		NW20-40-600NG	W552040
	50		NW20-50-600NG	W552050
	63		NW20-63-600NG	W552063
	75	NW20-75-600NG	W552075	
	100	NW20-100-600NG	W552010	
	125	NW20-125-600NG	W552012	
	150	NW20-150-600NG	W552015	

Thkns. T (mm)	Width W (mm)	Length L (mm)	Part Number	NAAMS Code
10	25	1000	NW10-25-1000NG	W571025
	40		NW10-40-1000NG	W571040
	50		NW10-50-1000NG	W571050
	63		NW10-63-1000NG	W571063
	75		NW10-75-1000NG	W571075
	100		NW10-100-1000NG	W571010
	125		NW10-125-1000NG	W571012
	150		NW10-150-1000NG	W571015
12	25		NW12-25-1000NG	W571225
	40		NW12-40-1000NG	W571240
	50		NW12-50-1000NG	W571250
	63		NW12-63-1000NG	W571263
	75		NW12-75-1000NG	W571275
	100		NW12-100-1000NG	W571210
	125		NW12-125-1000NG	W571212
	150		NW12-150-1000NG	W571215
15	25		NW15-25-1000NG	W571525
	40		NW15-40-1000NG	W571540
	50		NW15-50-1000NG	W571550
	63		NW15-63-1000NG	W571563
	75		NW15-75-1000NG	W571575
	100		NW15-100-1000NG	W571510
	125		NW15-125-1000NG	W571512
	150		NW15-150-1000NG	W571515
20	25		NW20-25-1000NG	W572025
	40		NW20-40-1000NG	W572040
	50		NW20-50-1000NG	W572050
	63		NW20-63-1000NG	W572063
	75	NW20-75-1000NG	W572075	
	100	NW20-100-1000NG	W572010	
	125	NW20-125-1000NG	W572012	
	150	NW20-150-1000NG	W572015	

# NW Series Self-Lubricating Wearstrips – Metric

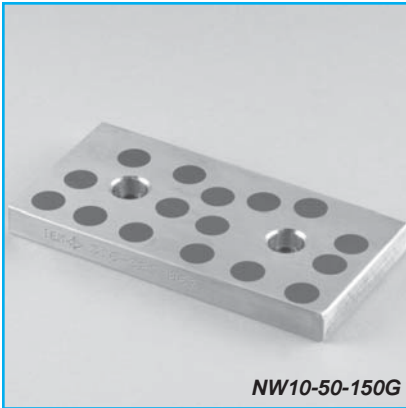

## Product Features

The NW Series of wearstrip fully conforms to the Chrysler die standards. They are manufactured in self-lubricating aluminum-bronze material and are available in 10, 12 and 15mm thicknesses and in 150 and 300mm lengths. They are supplied with mounting holes. For ease of identification, all products are marked with the part number.

### MATERIALS:

- Aluminum bronze material with oil impregnated graphite plugs. The plugs cover 25-30% of the wear surface and are arranged to generate optimal coverage at any engagement direction of the wearstrip.

### TOLERANCES:

- Thickness  $\pm 0.025$  mm
- Mounting hole locations  $\pm 0.13$  mm
- Unless otherwise noted  $\pm 0.25$  mm

### MOUNTING SCREWS:

- M6 S.H.C.S. recommended for 10mm thick strips
- M8 S.H.C.S. recommended for 12mm thick strips
- M10 S.H.C.S. recommended for 15mm thick strips

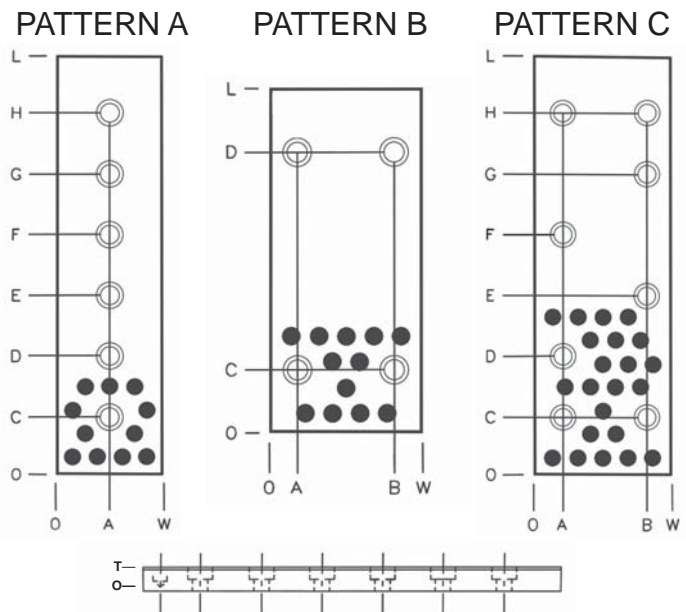

Width W (mm)	Length L (mm)	Thick T (mm)	Chrysler Code Number	Mounting Hole Pattern & Location									
				Hole Ptn.	A (mm)	B (mm)	C (mm)	D (mm)	E (mm)	F (mm)	G (mm)	H (mm)	
50	150	10	NW10-50-150G	19-296-1203	A	25	-	25	75	125	-	-	-
75		10	NW10-75-150G	19-296-1205	B	15	60		125	-	-	-	-
50		12	NW12-50-150G	19-296-1223	A	25	-		75	125	-	-	-
75		12	NW12-75-150G	19-296-1225	B	15	60		125	-	-	-	-
50		15	NW15-50-150G	19-296-1253	A	25	-		75	125	-	-	-
75		15	NW15-75-150G	19-296-1255	B	15	60		125	-	-	-	-
50	300	10	NW10-50-300G	19-296-1403	A	25	-	25	75	125	175	225	275
75		10	NW10-75-300G	19-296-1405	C	15	60						
50		12	NW12-50-300G	19-296-1423	A	25	-						
75		12	NW12-75-300G	19-296-1425	C	15	60						
50		15	NW15-50-300G	19-296-1453	A	25	-						
75		15	NW15-75-300G	19-296-1455	C	15	60						

# Self-Lubricating Gib Assemblies – Inch

## Product Features

The gib assembly includes four components: two L-gibs, a base plate, and an optional T-slide. The L-gibs are provided with screw holes and are spot drilled for dowels. Also, the base plate includes thru holes to allow for easy assembly and fit into a pre-machined pocket. The gib assembly is a proven performer in a wide variety of applications, including lifter slides in molds.

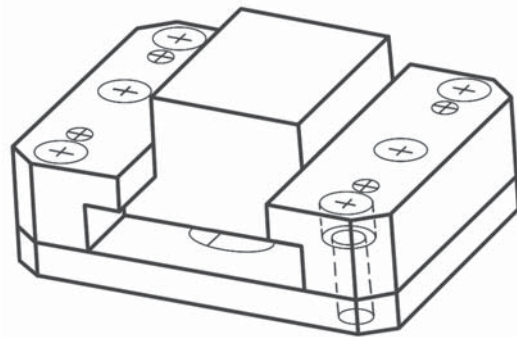
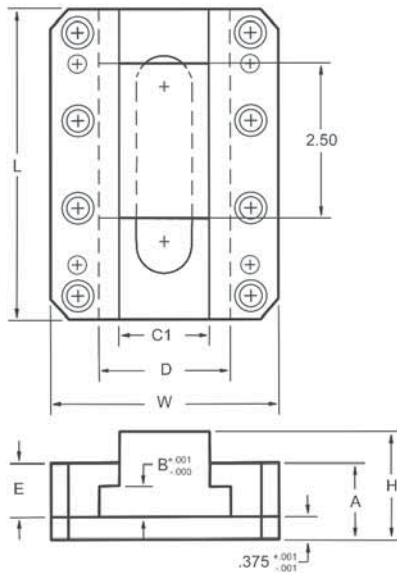

### NOTES:

- ◆ See pages 22-24 for more detailed specifications on L-Gibs, Base plates and T-Slides.

Gib Assembly w/ T-Slide Part Number	Gib Assembly w/OUT T-Slide Part Number	Length L (in)	Width W (in)	Mounting Hole Locations					
				A (in)	B (in)	C1 (in)	D (in)	E (in)	H (in)
2GA16GTS	2GA16GT	2.00	2.62	1.12	0.312	1.12	1.50	0.75	1.63
2GA24GTS	2GA24GT	3.00							
2GA32GTS	2GA32GT	4.00							
3GA24GTS	3GA24GT	3.00	3.12	1.12	0.575	0.12	1.62	0.75	1.62
3GA32GTS	3GA32GT	4.00							
3GA40GTS	3GA40GT	5.00							
4GA24GTS	4GA24GT	3.00	4.12	1.25	0.500	1.61	2.38	0.88	1.75
4GA32GTS	4GA32GT	4.00							
4GA40GTS	4GA40GT	5.00							
4GA48GTS	4GA48GT	6.00							
6GA32GTS	6GA32GT	4.00	4.62	1.63	0.750	1.62	2.62	1.25	2.13
6GA40GTS	6GA40GT	5.00							
6GA48GTS	6GA48GT	6.00							

# Self-Lubricating L-Gibs for Gib Assembly – Inch



## Product Features

These inch-sized L-gibs are used in the gib assemblies shown on page 21, or can be purchased separately to create custom cam systems. They are supplied with mounting holes and are spot drilled for dowels for simplified installation process.

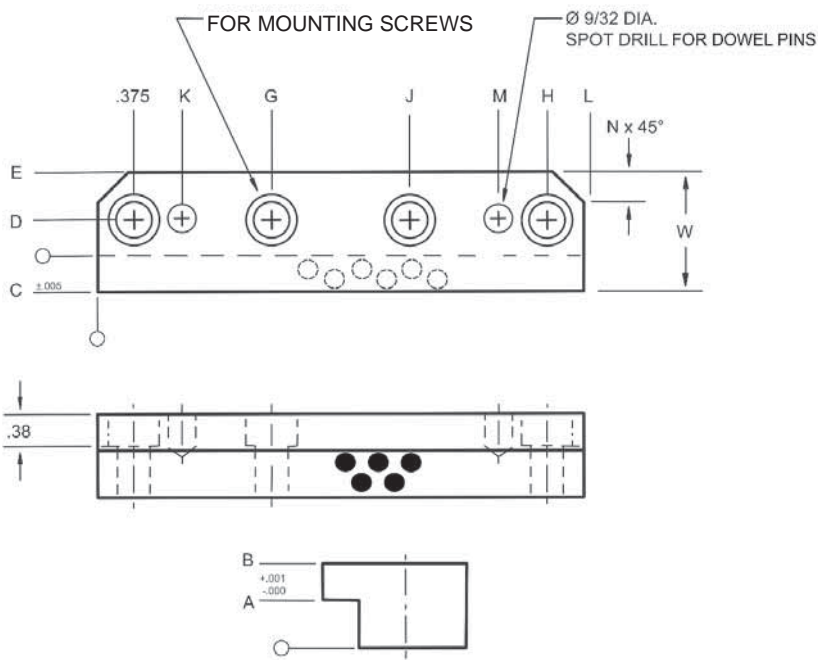

### MATERIALS:

- ◆ Aluminum bronze material with oil impregnated graphite plugs. The plugs cover 25-30% of the wear surface.

### TOLERANCES:

- ◆ Thickness ± 0.005 in.
- ◆ Mounting hole locations ± 0.005 in.
- ◆ Unless otherwise noted ± 0.010 in.

### MOUNTING SCREWS:

- ◆ 1/4" or M6 S.H.C.S recommended for 3/4" width GIBS.
- ◆ 5/16" or M8 S.H.C.S recommended for all other GIBS.

Gib Part Number	Length L (in)	Width W (in)	A (in)	B (in)	C (in)	D (in)	E (in)	G (in)	H (in)	J (in)	K (in)	M (in)	N (in)	Hole Qty.
2GAL16GT	2.00	0.750	0.312	0.750	0.188	0.28	0.56	–	1.625	–	1.00	–	0.26	2
2GAL24GT	3.00							–	2.625	–	0.88	2.12	0.26	2
2GAL32GT	4.00							2.000	3.625	–	0.88	3.12	0.26	3
3GAL24GT	3.00	1.000	0.375	0.75	0.250	0.37	0.75	–	2.625	–	0.88	2.12	0.26	2
3GAL32GT	4.00							2.000	3.625	–	0.88	3.12	0.26	3
3GAL40GT	5.00							2.500	4.625	–	0.88	4.12	0.26	3
4GAL24GT	3.00	1.255	0.500	0.88	0.375	0.37	0.88	–	2.625	–	0.88	2.12	0.32	2
4GAL32GT	4.00							2.000	3.625	–	0.88	3.12	0.32	3
4GAL40GT	5.00							2.500	4.625	–	0.88	4.12	0.32	3
4GAL48GT	6.00							2.125	5.625	3.875	0.88	5.12	0.32	4
6GAL32GT	4.00	1.500	0.750	1.25	0.500	0.44	1.00	2.000	3.625	–	0.88	3.12	0.32	3
6GAL40GT	5.00							2.500	4.625	–	0.88	4.12	0.32	3
6GAL48GT	6.00							2.125	5.625	3.875	0.88	5.12	0.32	4



# Self-Lubricating Baseplate for Gib Assembly – Inch

## Product Features

These inch-sized Baseplates are used in the gib assemblies shown on page 21, or can be purchased separately to create custom cam systems. For ease of assembly, they are supplied with thru holes.

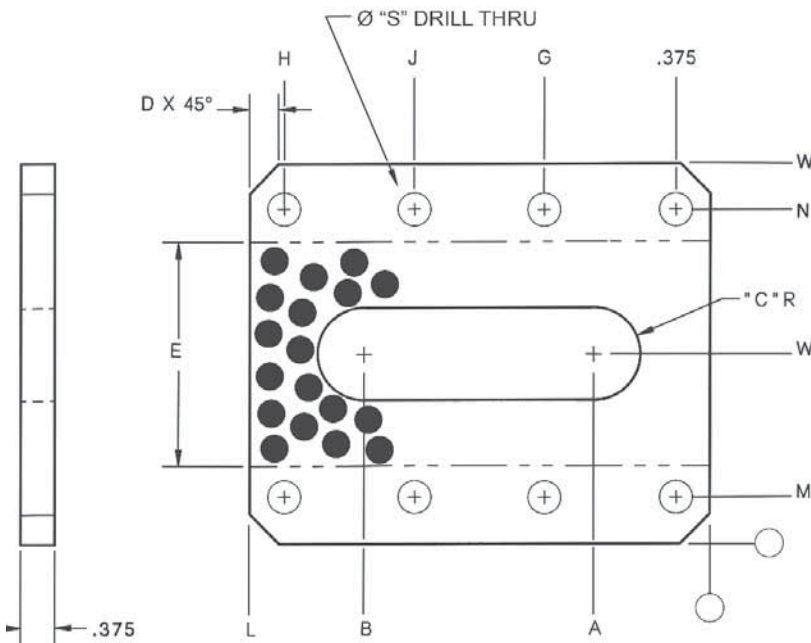

### MATERIALS:

- ◆ Aluminum bronze material with oil impregnated graphite plugs. The plugs cover 25-30% of the wear surface.

### TOLERANCES:

- ◆ Thickness  $\pm 0.005$  in.
- ◆ Mounting hole locations  $\pm 0.005$  in.
- ◆ Flatness  $\pm 0.001$  in.
- ◆ Unless otherwise noted  $\pm 0.010$  in.

Base Part Number	Length L (in)	Width W (in)	A (in)	B (in)	C (in)	D (in)	E (in)	G (in)	H (in)	J (in)	M (in)	N (in)	Hole Qty.	S (in)
2GAB16GT	2.00	2.62	0.69	1.31	0.38	0.26	1.50	–	1.625	–	0.28	2.34	4	.28
2GAB24GT	3.00		0.88	2.12				–	2.625	–			6	
2GAB32GT	4.00		1.00	3.00				2.00	3.625	–			6	
3GAB24GT	3.00	3.12	1.00	2.00	0.38	0.26	1.68	–	2.625	–	0.38	2.74	4	.38
3GAB32GT	4.00			3.00	0.50			2.00	3.625	–			6	
3GAB40GT	5.00			4.00	0.50			2.50	4.625	–			6	
4GAB24GT	3.00	4.12	1.00	2.00	0.50	0.32	2.44	–	2.625	–	0.50	3.62	4	.38
4GAB32GT	4.00			3.00				2.00	3.625	–			6	
4GAB40GT	5.00			4.00				2.50	4.625	–			6	
4GAB48GT	6.00			5.00				2.125	5.625	3.875			8	
6GAB32GT	4.00	4.62	1.00	3.00	0.50	0.32	2.75	2.00	3.625	–	0.56	4.06	6	.38
6GAB40GT	5.00			4.00				2.50	4.625	–			6	
6GAB48GT	6.00			5.00				2.13	5.625	3.875			8	

# Optional T-Slide for Gib Assembly – Inch

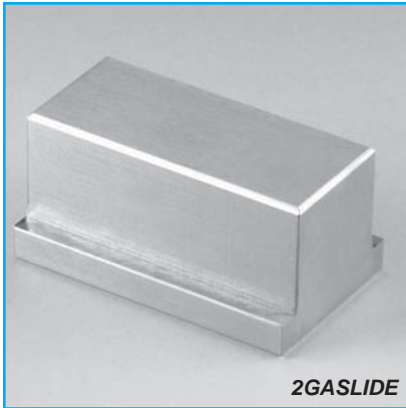

## Product Features

The inch-sized T-Slide is often used as a Lifter Slide and can be purchased separately or as a part of the gib assembly on page 21.

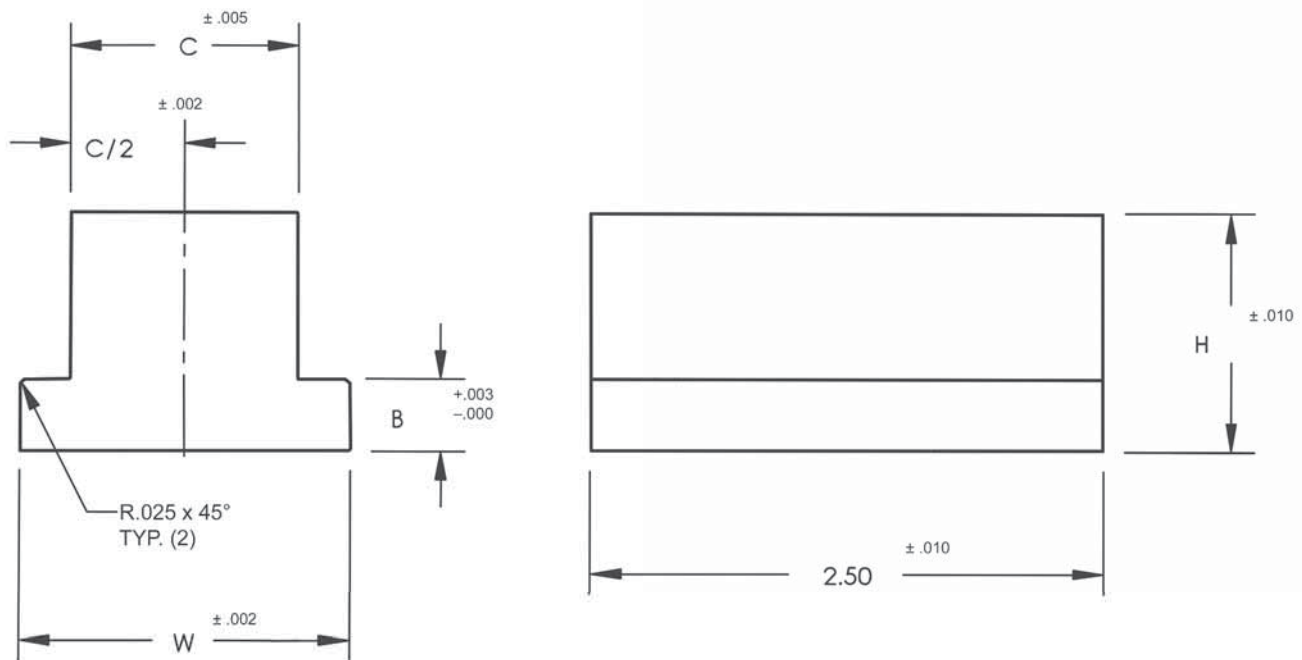

Part Number	Width W (in)	B (in)	C (in)	C/2 (in)	Height H (in)
2GASLIDE	1.493	0.308	1.110	0.555	1.25
3GASLIDE	1.617	0.371	1.110	0.555	1.25
4GASLIDE	2.367	0.496	1.610	0.805	1.38
6GASLIDE	2.617	0.746	1.610	0.805	1.75

### MATERIALS:

- ◆ High quality carburized steel.

# Self-Lubricating Square Gibs – Inch

## Product Features

These self-lubricating square gibs are manufactured in inch sizes from 1" to 2" wide and in lengths up to 12". They come standard with mounting holes for ease of assembly. The 12" lengths are available with or without mounting holes.



8SG32G

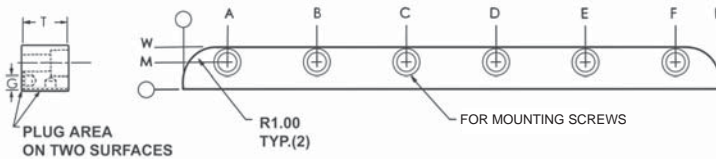

### MATERIALS:

- ◆ Aluminum bronze material with oil-impregnated graphite plugs. The plugs cover 25-30% of the wear surface.

### TOLERANCES:

- ◆ Unless otherwise noted  $\pm 0.010$  in.

### MOUNTING SCREWS:

- ◆ 3/8" S.H.C.S recommended
- ◆ Part numbers 6SG96NG, 8SG96NG and 12SG96NG do not include mounting holes.

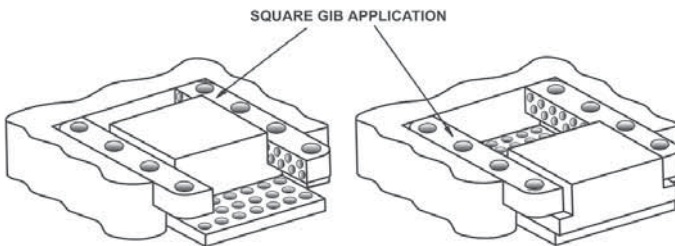

Part Number	L (in)	W (in)	T (in)	Mounting Hole Pattern & Location							G (in)
				A (in)	B (in)	C (in)	D (in)	E (in)	F (in)	M (in)	
6SG32G	4.00	1.00	0.75	1.00	2.00	3.00	-	-	-	0.625	0.39
6SG40G	5.00				2.50	4.00	-	-	-		
6SG48G	6.00				3.00	5.00	-	-	-		
6SG64G	8.00				3.00	5.00	7.00	-	-		
6SG80G	10.00				3.00	5.00	7.00	9.00	-		
6SG96G	12.00				3.00	5.00	7.00	9.00	11.00		
6SG96NG	12.00			-	-	-	-	-	-	-	-
8SG32G	4.00	1.25	1.00	1.00	2.00	3.00	-	-	-	0.875	0.62
8SG40G	5.00				2.50	4.00	-	-	-		
8SG48G	6.00				3.00	5.00	-	-	-		
8SG64G	8.00				3.00	5.00	7.00	-	-		
8SG80G	10.00				3.00	5.00	7.00	9.00	-		
8SG96G	12.00				3.00	5.00	7.00	9.00	11.00		
8SG96NG	12.00			-	-	-	-	-	-	-	
12SG64G	8.00	2.00	1.50	1.50	4.00	6.50	-	-	-	0.625	0.86
12SG80G	10.00			1.25	3.75	6.25	8.75	-	-		
12SG96G	12.00			1.50	4.50	7.50	10.50	-	-		
12SG96NG	12.00			-	-	-	-	-	-	-	

# Self-Lubricating L-Gibs – Inch

## Product Features

These self-lubricating L-Gibs are manufactured in inch sizes from 3/4" to 3" wide and in lengths up to 24". They are available with or without mounting holes.



3LG48G

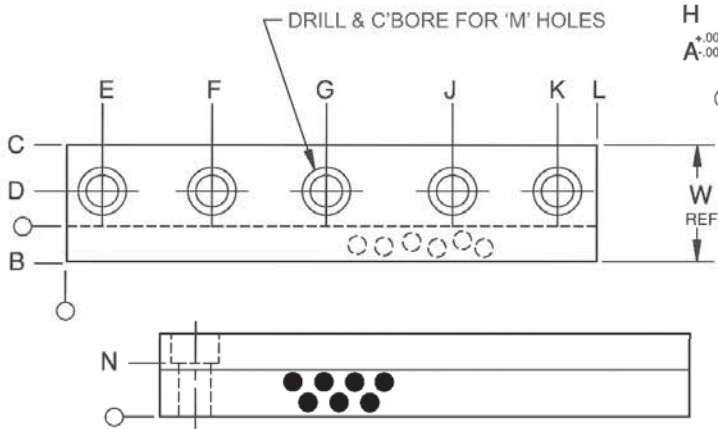

### MATERIALS:

- ◆ Aluminum bronze material with oil-impregnated graphite plugs. The plugs cover 25-30% of the wear surface.

### TOLERANCES:

- ◆ Mounting hole locations  $\pm 0.010$  in.
- ◆ Unless otherwise noted  $\pm 0.010$  in.

Part # with Mounting Holes	Part # W/O Mounting Holes	Length L (in)	Width W (in)	Height H (in)	Mounting Hole Pattern & Location											
					A (in)	B (in)	C (in)	D (in)	E (in)	F (in)	G (in)	J (in)	K (in)	M		N (in)
											# holes	size				
2LG42G	2LG42NG	5.25	0.75	0.75	0.312	0.18	0.56	0.28	0.88	–	2.62	–	4.38	3	1/4 or M6	.25
2LG56G	2LG56NG	7.00							0.88	2.62	–	4.38	6.12	4		
2LG70G	2LG70NG	8.75							0.88	2.62	4.38	6.12	7.88	5		
3LG48G	3LG48NG	6.00	1.00	0.75	0.375	0.25	0.75	0.38	1.00	–	3.00	–	5.00	3	5/16 or .31 M8	
3LG64G	3LG64NG	8.00							1.00	3.00	–	5.00	7.00	4		
3LG80G	3LG80NG	10.00							1.00	3.00	5.00	7.00	9.00	5		
4LG48G	4LG48NG	6.00	1.25	0.88	0.500	0.38	0.88	0.44	1.00	–	3.00	–	5.00	3	3/8 or M10	.50
4LG60G	4LG60NG	7.50							1.25	–	3.75	–	6.25	3		
4LG80G	4LG80NG	10.00							1.25	3.75	–	6.25	8.75	4		
4LG100G	4LG100NG	12.50							1.25	3.75	6.25	8.75	11.25	5		
6LG48G	6LG48NG	6.00	1.50	1.25	0.750	0.50	1.00	0.50	1.00	–	3.00	–	5.00	3	3/8 or M10	.75
6LG72G	6LG72NG	9.00							1.50	–	4.50	–	7.50	3		
6LG96G	6LG96NG	12.00							1.50	4.50	–	7.50	10.50	4		
6LG120G	6LG120NG	15.00							1.50	4.50	7.50	10.50	13.50	5		
7LG64G	7LG64NG	8.00	2.00	1.50	0.875	0.62	1.37	0.68	1.00	3.00	–	5.00	7.00	4	1/2 or M12	.75
7LG96G	7LG96NG	12.00							1.50	4.50	–	7.50	10.50	4		
7LG128G	7LG128NG	16.00							2.00	6.00	–	10.00	14.00	4		
10LG96G	10LG96NG	12.00	2.50	2.00	1.250	0.75	1.75	0.88	1.50	4.50	–	7.50	10.50	4	5/8 or M16	1.25
10LG144G	10LG144NG	18.00							2.25	6.75	–	11.25	15.75	4		
10LG192G	10LG192NG	24.00							3.00	9.00	–	15.00	21.00	4		
12LG96G	12LG96NG	12.00	3.00	2.50	1.500	1.00	2.00	1.00	1.50	4.50	–	7.50	10.50	4	5/8 or M16	1.75
12LG144G	12LG144NG	18.00							2.25	6.75	–	11.25	15.75	4		
12LG192G	12LG192NG	24.00							3.00	9.00	–	15.00	21.00	4		

# Self-Lubricating L-Gibs – Metric

## Product Features

These self-lubricating L-Gibs are manufactured in metric sizes in 32 and 50mm widths and in lengths up to 350mm. They come standard with mounting holes to accommodate an M10 S.H.C.S.

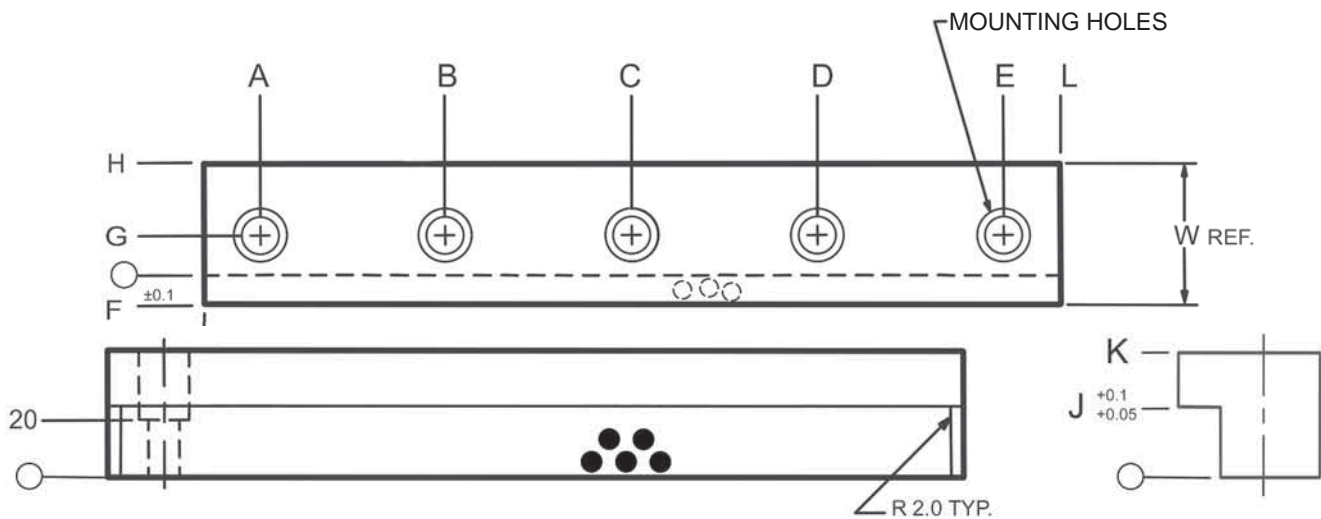

### MATERIALS:

- ◆ Aluminum bronze material with oil-impregnated graphite plugs. The plugs cover 25-30% of the wear surface.

### TOLERANCES:

- ◆ Unless otherwise noted  $\pm 0.25$  in.

### MOUNTING SCREWS:

- ◆ M10 S.H.C.S. recommended. 11mm through hole, 18mm Counterbore.

Part Number	FIAT Code #	Length L (mm)	Width W (mm)	Mounting Hole Location										Hole Qty.
				A (mm)	B (mm)	C (mm)	D (mm)	E (mm)	F (mm)	G (mm)	H (mm)	J (mm)	K (mm)	
15LG100G	BR-15	100	32	20	-	-	-	80	10	11	22	15	30	2
15LG150G	BR-16	150			-	75	-	130						3
15LG200G	-	200			75	-	125	180						4
15LG250G	-	250			90	-	160	230						4
25LG200G	BR-17	200	50	20	75	-	125	180	22	14	28	25	45	-
25LG250G	BR-18	250			90	-	160	230						-
25LG300G	-	300			85	150	215	280						-
25LG350G	-	350			100	175	250	330						-

# Self-Lubricating 10mm LIP Cam Slide Gibs



## Product Features

These Gibs fully conform to the NAAMS standard. They are manufactured from hardened steel with graphite plugs for self-lubricating operation. They are available with dowel holes for location. For ease of identification, all plates are marked with the part number and NAAMS code.

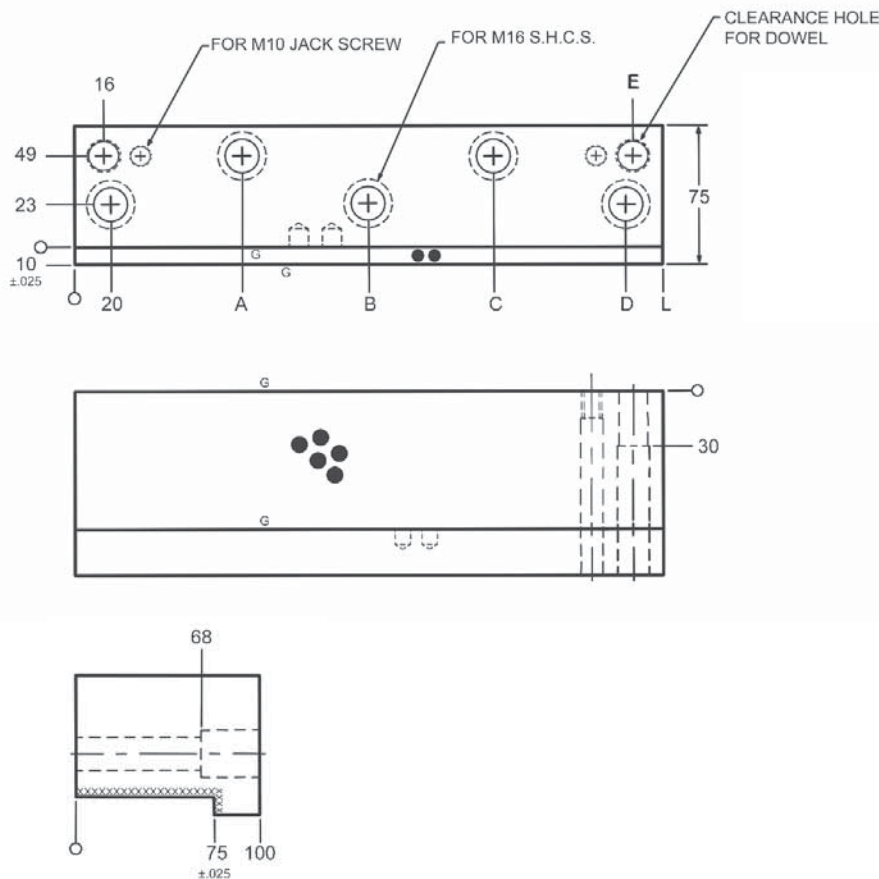

### MATERIALS:

- ◆ Manufactured from high quality carburized steel precision ground and hardened to Rc56-62 with oil-impregnated graphite plugs covering 20-30% of the wear surface.

### TOLERANCES:

- ◆ Mounting hole locations  $\pm 0.25\text{mm}$
- ◆ Dowel hole locations  $\pm 0.10\text{mm}$
- ◆ Unless otherwise noted:  $\pm 0.25\text{mm}$
- ◆ Break edges  $0.4 \times 45^\circ$

### MOUNTING SCREWS:

- ◆ M16 S.H.C.S. recommended for mounting
- ◆ M16 dowel holes optional

Part Number	NAAMS Code	Length L (mm)	Hole Quantity	Mounting Hole Location				
				A	B	C	D	E
Q75KF160GL	R127516	160	3	–	80	–	140	144
Q75KF200GL	R127520	200	3	–	100	–	180	184
Q75KF250GL	R127525	250	4	90	–	160	230	234
Q75KF315GL	R127531	315	5	89	157	225	295	299

**NOTE:** Remove "Q" prefix for unfinished dowel holes.



# Self-Lubricating 13mm LIP Cam Slide Gibs

## Product Features

These Gibs fully conform to the NAAMS standard. They are manufactured from hardened steel with graphite plugs for self-lubricating operation. They are available with dowel holes for location. For ease of identification, all plates are marked with the part number and NAAMS code.

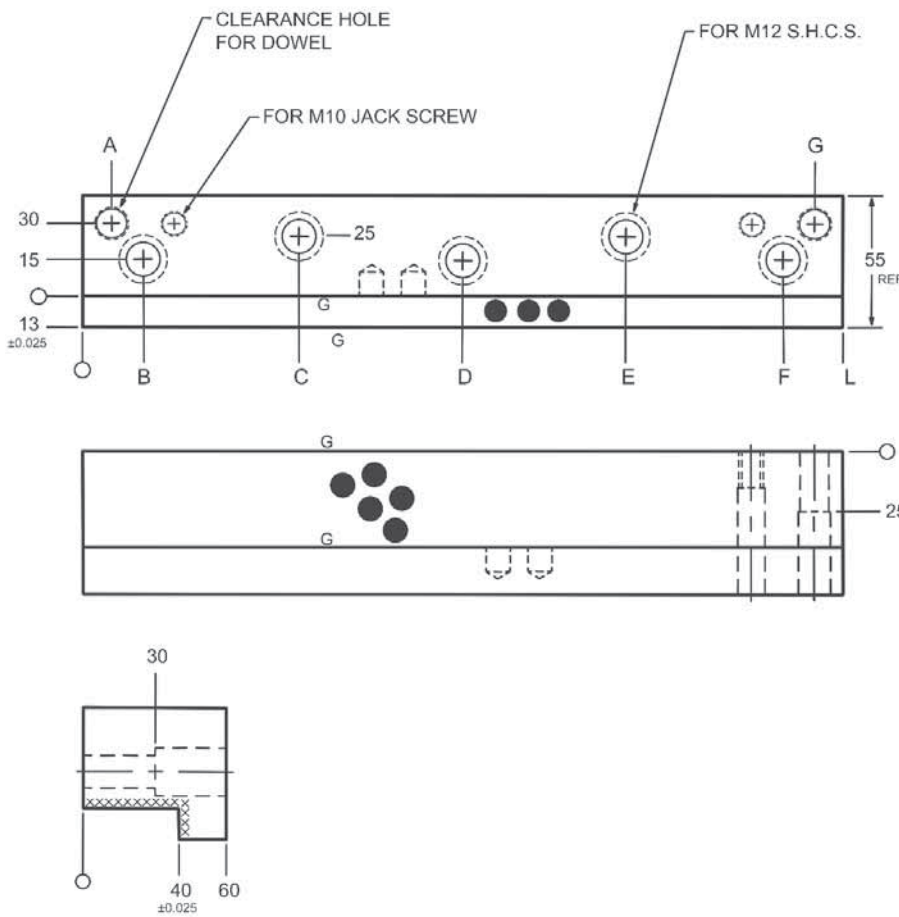

### MATERIALS:

- ◆ Manufactured from high quality carburized steel precision ground and hardened to Rc56-62 with oil-impregnated graphite plugs covering 20-30% of the wear surface.

### TOLERANCES:

- ◆ Mounting hole locations  $\pm 0.25\text{mm}$
- ◆ Dowel hole locations  $\pm 0.10\text{mm}$
- ◆ Unless otherwise noted:  $\pm 0.25\text{mm}$
- ◆ Break edges  $0.4 \times 45^\circ$

### MOUNTING SCREWS:

- ◆ M12 S.H.C.S. recommended for mounting
- ◆ M12 dowel holes optional

Part Number	NAAMS Code	Length L (mm)	Hole Quantity	Mounting Hole Location						
				A	B	C	D	E	F	G
Q40KF160GL	R114016	160	3	12	25	80	–	–	135	148
Q40KF200GL	R114020	200	3	12	25	100	–	–	175	188
Q40KF250GL	R114025	250	4	12	25	90	–	160	225	238
Q40KF315GL	R114031	315	5	12	25	90	157.5	225	290	303

**NOTE:** Remove "Q" prefix for unfinished dowel holes.



# Self-Lubricating U & V Blocks – Inch

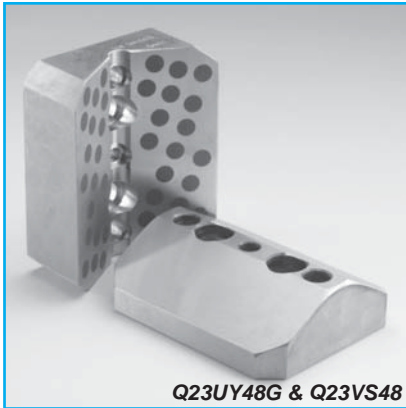

## Product Features

These U and V Blocks are manufactured to inch dimensions. The V Block is manufactured from hardened steel and the U block is self-lubricating aluminum bronze with oil-impregnated graphite plugs. The blocks are provided with 1/2" dowel holes and are drilled and counterbored to accommodate 1/2" S.H.C.S. for mounting.

**FIGURE A**  
Aluminum  
Bronze  
U-Block

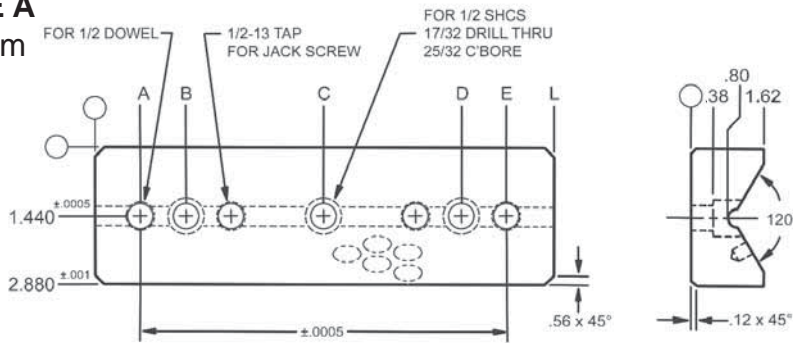

### MATERIALS:

- ◆ V Blocks are manufactured from high quality carburized steel. They are precision ground and hardened to Rc56-62.
- ◆ U Blocks are manufactured from aluminum bronze material with oil-impregnated graphite plugs.

**FIGURE B**  
Steel  
V-Block

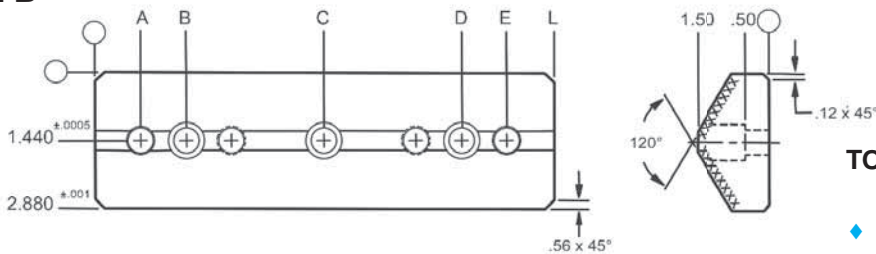

### TOLERANCES:

- ◆ Unless otherwise noted ± 0.010 in.

**FIGURE C**  
Assembly

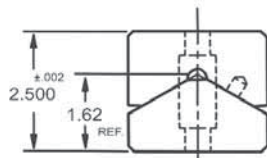

### MOUNTING SCREWS:

- ◆ 1/2" S.H.C.S. recommended for mounting. Plate has 17/32" drill through 25/32" counterbore.

U Block Part Number	V Block Part Number	Length L (in)	Mounting Hole Qty.	Mounting Hole Locations				
				A (in)	B (in)	C (in)	D (in)	E (in)
Q23UY48G	Q23VS48	6.00	2	0.75	1.75	–	4.25	5.25
Q23UY64G	Q23VS64	8.00	2	1.00	2.00	–	6.00	7.00
Q23UY80G	Q23VS80	10.00	3	1.00	2.00	5.00	8.00	9.00

# Self-Lubricating U & V Blocks – Inch

## Product Features

These U and V Blocks are manufactured to inch dimensions. The V Block is manufactured from hardened steel and the U block is self-lubricating aluminum bronze with oil-impregnated graphite plugs. The blocks are provided with 5/8" dowel holes and are drilled and counterbored to accommodate 5/8" S.H.C.S. for mounting.

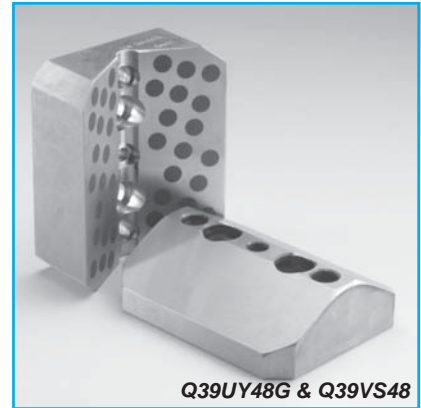

**FIGURE A**  
Aluminum  
Bronze  
U-Block

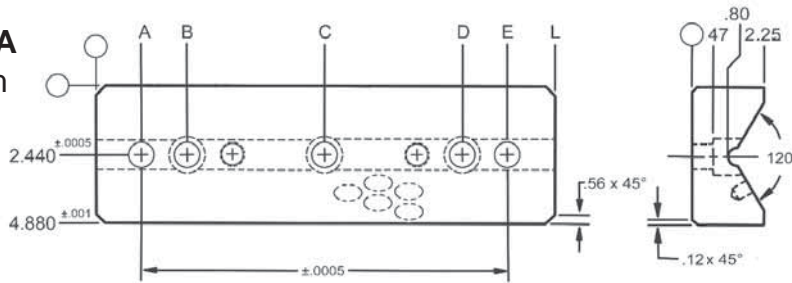

**FIGURE B**  
Steel  
V-Block

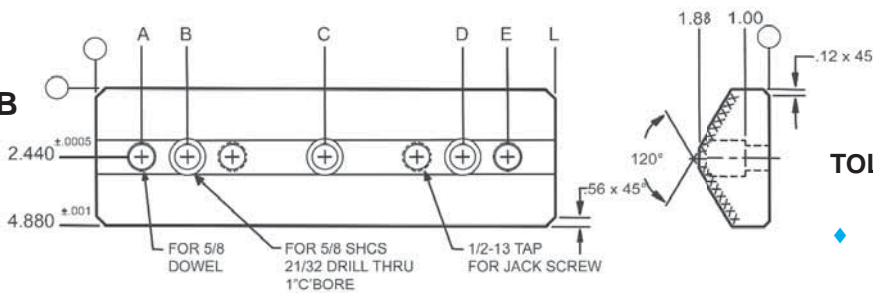

**FIGURE C**  
Assembly

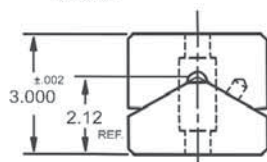

### MATERIALS:

- ◆ V Blocks are manufactured from high quality carburized steel. They are precision ground and hardened to Rc56-62.
- ◆ U Blocks are manufactured from aluminum bronze material with oil-impregnated graphite plugs.

### TOLERANCES:

- ◆ Unless otherwise noted  $\pm 0.010$  in.

### MOUNTING SCREWS:

- ◆ 5/8" S.H.C.S. recommended for mounting. Plate has 21/32" drill through 1" counterbore.

U Block Part Number	V Block Part Number	Length L (in)	Mounting Hole Qty.	Mounting Hole Locations				
				A (in)	B (in)	C (in)	D (in)	E (in)
Q39UY48G	Q39VS48	6.00	2	0.75	1.75	–	4.25	5.25
Q39UY64G	Q39VS64	8.00	2	1.00	2.00	–	6.00	7.00
Q39UY80G	Q39VS80	10.00	3	1.00	2.00	5.00	8.00	9.00

# NAAMS U & V Blocks – Metric



## Product Features

These 65, 75, 125 and 175mm U and V Blocks are manufactured to metric dimensions and fully meet the NAAMS standard. The U Block is manufactured from hardened steel. The V block is self-lubricating in design and is available in either aluminum bronze with oil-impregnated graphite plugs or steel with oil-impregnated graphite plugs.

**FIGURE A - Steel U Block**

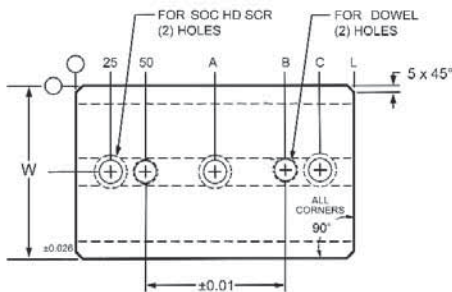

**FIGURE B - Self-lubricating V Block**

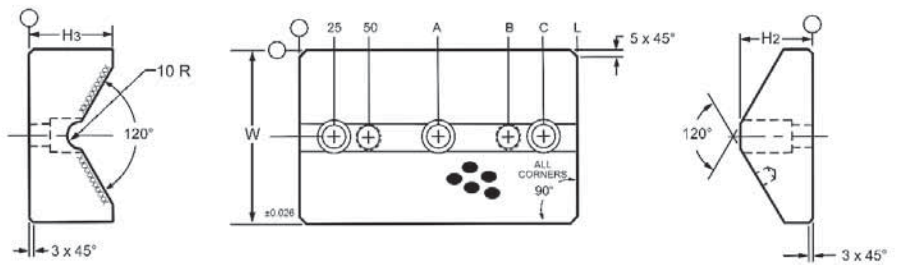

**FIGURE C - Assembly**

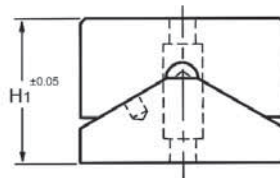

### MATERIALS:

- ◆ U Blocks are manufactured from high quality carburized steel. They are precision ground and hardened to Rc56-62.
- ◆ V Blocks are manufactured from aluminum bronze material with oil-impregnated graphite plugs or steel with oil-impregnated graphite plugs.

### TOLERANCES:

- ◆ Between screw holes: ± 0.12mm
- ◆ Between dowel holes: ± 0.10mm
- ◆ Unless otherwise noted: ± 0.25mm

### RECOMMENDED MOUNTING SCREWS & DOWELS:

- ◆ **65mm blocks:** M12 S.H.C.S./M12 DOWELS
- ◆ **75mm blocks:** M12 S.H.C.S. /M12 DOWELS
- ◆ **125mm blocks:** M16 S.H.C.S. M16 DOWELS
- ◆ **175mm blocks:** M16 S.H.C.S. M16 DOWELS

# NAAMS

## U & V Blocks – Metric

U Block		Steel V Block		Bronze V Block		Width W (mm)	Length L (mm)	Hole Qty.	A (mm)	B (mm)	C (mm)	H1 (mm)	H2 (mm)	H3 (mm)
Part Number	NAAMS Code	Part Number	NAAMS Code	Part Number	NAAMS Code									
Q65US150	G157515	Q65VS150G	G167515	Q65VY150G	G177515	65	150	2	-	100	125	65	39	40
Q65US200	G157520	Q65VS200G	G167520	Q65VY200G	G177520	65	200	2	-	150	175	65	39	40
Q65US250	G157525	Q65VS250G	G167525	Q65VY250G	G177525	65	250	3	125	200	225	65	39	40
Q65US300	G157530	Q65VS300G	G167530	Q65VY300G	G177530	65	300	3	150	250	275	65	39	40
Q75US150	G217515	Q75VS150G	G227515	Q75VY150G	G237515	75	150	2	-	100	125	65	39	40
Q75US200	G217520	Q75VS200G	G227520	Q75VY200G	G237520	75	200	2	-	150	175	65	39	40
Q75US250	G217525	Q75VS250G	G227525	Q75VY250G	G237525	75	250	3	125	200	225	65	39	40
Q75US300	G217530	Q75VS300G	G227530	Q75VY300G	G237530	75	300	3	150	250	275	65	39	40
Q125US150	G311215	Q125VS150G	G321215	Q125VY150G	G331215	125	150	2	-	100	125	85	52	60
Q125US200	G311220	Q125VS200G	G321220	Q125VY200G	G331220	125	200	2	-	150	175	85	52	60
Q125US250	G311225	Q125VS250G	G321225	Q125VY250G	G331225	125	250	3	125	200	225	85	52	60
Q125US300	G311230	Q125VS300G	G321230	Q125VY300G	G331230	125	300	3	150	250	275	85	52	60
Q175US150	G341715	Q175VS150G	G351715	Q175VY150G	G361715	175	150	2	-	100	125	110	67	80
Q175US200	G341720	Q175VS200G	G351720	Q175VY200G	G361720	175	200	2	-	150	175	110	67	80

# Self-Lubricating 45mm Guide Blocks – Metric



## Product Features

These guide blocks fully meet the NAAMS standard. The oil-impregnated graphite plugs cover 20-30% of the wear surface, ensuring self-lubrication. They are available with or without dowel holes. For ease of identification, all parts are marked with the part number and NAAMS code.

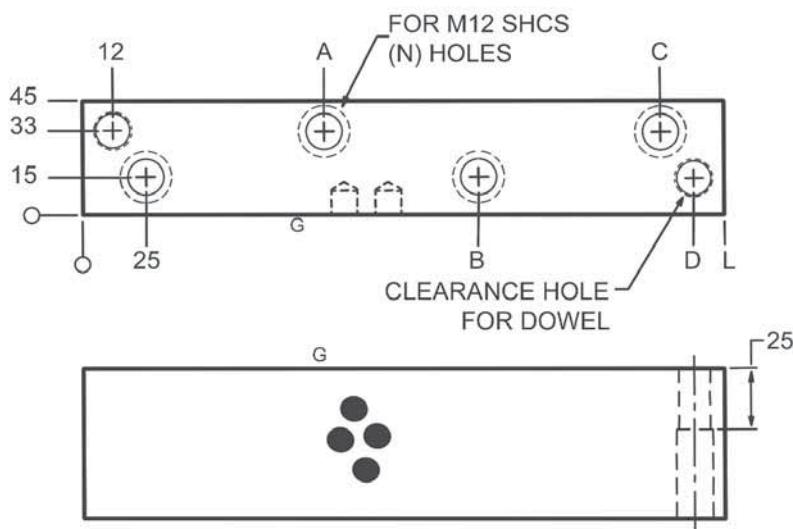

### MATERIALS:

- ◆ High quality carburized steel with oil-impregnated graphite plugs. They are precision ground and hardened to Rc56-62.

### TOLERANCES:

- ◆ Mounting hole locations  $\pm 0.25\text{mm}$
- ◆ Dowel holes  $\pm 0.10\text{mm}$

### MOUNTING SCREWS:

- ◆ M12 S.H.C.S. recommended for mounting.

# Self-Lubricating 45mm Guide Blocks – Metric

Part Number	NAAMS Code	Length L (mm)	Hole Qty.	Mounting Hole Location				E (mm)	F (mm)
				A (mm)	B (mm)	C (mm)	D (mm)		
Q40G75G	G 014007	75	2	–	–	50	63	40	25
Q40G100G	G 014010	100	2	–	–	75	88		
Q40G125G	G 014012	125	3	–	62.5	100	113		
Q40G150G	G 014015	150	3	–	75.0	125	138		
Q40G175G	G 014017	175	3	–	87.5	150	163		
Q40G200G	G 014020	200	4	75	125.0	175	188		
Q40G225G	G 014022	225	4	85	140.0	200	213		
Q40G250G	G 014025	250	4	95	165.0	225	238		
Q45G75G	G 014507	75	2	–	–	50	63	45	20
Q45G100G	G 014510	100	2	–	–	75	88		
Q45G125G	G 014512	125	3	–	62.5	100	113		
Q45G150G	G 014515	150	3	–	75.0	125	138		
Q45G175G	G 014517	175	3	–	87.5	150	163		
Q45G200G	G 014520	200	4	75	125.0	175	188		
Q45G225G	G 014522	225	4	85	140.0	200	213		
Q45G250G	G 014525	250	4	95	165.0	225	238		
Q50G75G	G 015007	75	2	–	–	50	63	50	20
Q50G100G	G 015010	100	2	–	–	75	88		
Q50G125G	G 015012	125	3	–	62.5	100	113		
Q50G150G	G 015015	150	3	–	75.0	125	138		
Q50G175G	G 015017	175	3	–	87.5	150	163		
Q50G200G	G 015020	200	4	75	125.0	175	188		
Q50G225G	G 015022	225	4	85	140.0	200	213		
Q50G250G	G 015025	250	4	95	165.0	225	238		
Q60G75G	G 016007	75	2	–	–	50	63	60	30
Q60G100G	G 016010	100	2	–	–	75	88		
Q60G125G	G 016012	125	3	–	62.5	100	113		
Q60G150G	G 016015	150	3	–	75.0	125	138		
Q60G175G	G 016017	175	3	–	87.5	150	163		
Q60G200G	G 016020	200	4	75	125.0	175	188		
Q60G225G	G 016022	225	4	85	140.0	200	213		
Q60G250G	G 016025	250	4	95	165.0	225	238		
Q75G75G	G 017507	75	2	–	–	50	63	75	45
Q75G100G	G 017510	100	2	–	–	75	88		
Q75G125G	G 017512	125	3	–	62.5	100	113		

# Self-Lubricating 60mm Guide Blocks – Metric



## Product Features

These guide blocks fully meet the NAAMS standard. The oil-impregnated graphite plugs cover 20-30% of the wear surface, ensuring self-lubrication. They are available with or without dowel holes. For ease of identification, all parts are marked with the part number and NAAMS code.

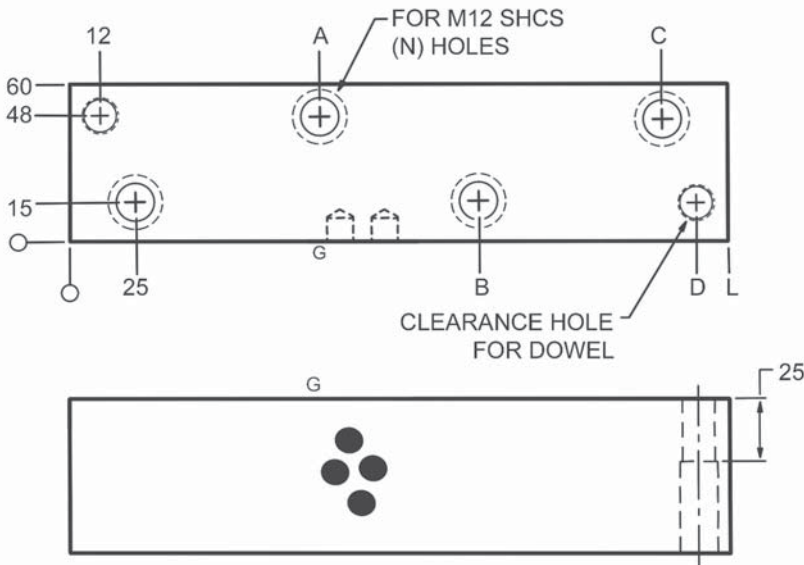

### MATERIALS:

- ◆ High quality carburized steel with oil-impregnated graphite plugs. They are precision ground and hardened to Rc56-62.

### TOLERANCES:

- ◆ Mounting hole locations  $\pm 0.25\text{mm}$
- ◆ Dowel holes  $\pm 0.10\text{mm}$

### MOUNTING SCREWS:

- ◆ M12 S.H.C.S. recommended for mounting.



# Self-Lubricating 60mm Guide Blocks – Metric

Part Number	NAAMS Code	Length L (mm)	Hole Qty.	Mounting Hole Location				E (mm)	F (mm)
				A (mm)	B (mm)	C (mm)	D (mm)		
Q50GH75G	G 025007	75	2	–	–	50	63	50	20
Q50GH100G	G 025010	100	2	–	–	75	88		
Q50GH125G	G 025012	125	3	–	62.5	100	113		
Q50GH150G	G 025015	150	3	–	75.0	125	138		
Q50GH175G	G 025017	175	3	–	87.5	150	163		
Q50GH200G	G 025020	200	4	75	125.0	175	188		
Q50GH225G	G 025022	225	4	85	140.0	200	213		
Q50GH250G	G 025025	250	4	95	165.0	225	238		
Q60GH75G	G 026007	75	2	–	–	50	63	60	30
Q60GH100G	G 026010	100	2	–	–	75	88		
Q60GH125G	G 026012	125	3	–	62.5	100	113		
Q60GH150G	G 026015	150	3	–	75.0	125	138		
Q60GH175G	G 026017	175	3	–	87.5	150	163		
Q60GH200G	G 026020	200	4	75	125.0	175	188		
Q60GH225G	G 026022	225	4	85	140.0	200	213		
Q60GH250G	G 026025	250	4	95	165.0	225	238		
Q80GH75G	G 028007	75	2	–	–	50	63	80	50
Q80GH100G	G 028010	100	2	–	–	75	88		
Q80GH125G	G 028012	125	3	–	62.5	100	113		
Q80GH150G	G 028015	150	3	–	75.0	125	138		
Q80GH175G	G 028017	175	3	–	87.5	150	163		
Q80GH200G	G 028020	200	4	75	125.0	175	188		
Q80GH225G	G 028022	225	4	85	140.0	200	213		
Q80GH250G	G 028025	250	4	95	165.0	225	238		
Q100GH75G	G 020007	75	2	–	–	50	63	100	70
Q100GH100G	G 020010	100	2	–	–	75	88		
Q100GH125G	G 020012	125	3	–	62.5	100	113		
Q100GH150G	G 020015	150	3	–	75.0	125	138		
Q100GH175G	G 020017	175	3	–	87.5	150	163		
Q100GH200G	G 020020	200	4	75	125.0	175	188		
Q100GH225G	G 020022	225	4	85	140.0	200	213		
Q100GH250G	G 020025	250	4	95	165.0	225	238		

# Medium Duty Self-Lubricating Guide Blocks – Inch



## Product Features

These medium duty guide blocks are manufactured from hardened steel with oil-impregnated graphite plugs covering 20-30% of the wear surface. The blocks are supplied with mounting holes for 1/2" S.H.C.S. All blocks are marked with the part number for ease of identification.

### FOR 3.0" & 4.0" LENGTHS

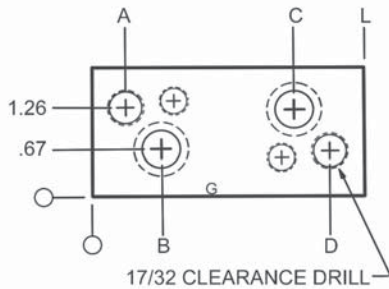

### FOR 5.0" & 6.0" LENGTHS

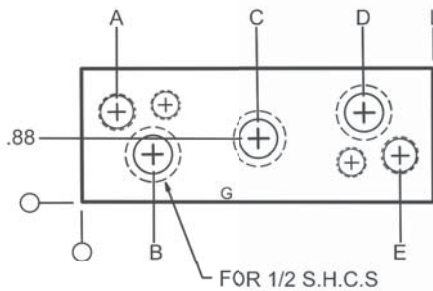

### FOR 8.0" TO 10.0" LENGTHS

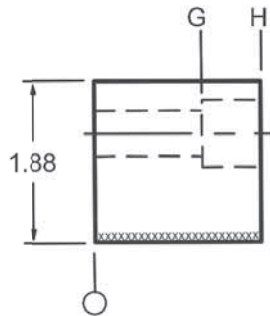
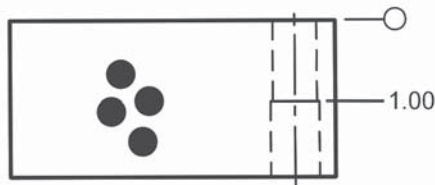
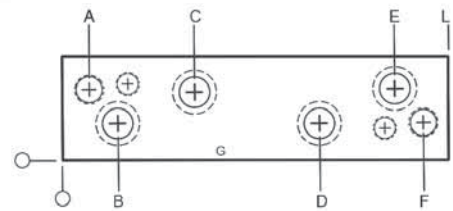

#### MATERIALS:

- ◆ High quality carburized steel with oil-impregnated graphite plugs. They are precision ground and hardened to Rc56-62.

#### MOUNTING SCREWS:

- ◆ 1/2" S.H.C.S. recommended for mounting

# Medium Duty Self-Lubricating Guide Blocks – Inch

GENERAL DIMENSIONS	Length L (in)	Mounting Hole Quantity	Mounting Hole Location					
			A (in)	B (in)	C (in)	D (in)	E (in)	F (in)
	3.00	2	.50	1.00	2.00	2.50	–	–
	4.00	3			3.00	3.50	–	–
	5.00	3			2.50	4.00	4.50	–
	6.00	3			3.00	5.00	5.50	–
	8.00	4			2.38	5.62	7.00	7.50
	10.00	4			3.50	6.50	9.00	9.50

Part Number	Length L (in)	G (in)	H (in)
14G24G	3	1.00	1.69
14G32G	4		
14G40G	5		
14G48G	6		
14G64G	8		
14G80G	10		
16G24G	3	1.25	1.94
16G32G	4		
16G40G	5		
16G48G	6		
16G64G	8		
16G80G	10		
20G24G	3	1.25	2.44
20G32G	4		
20G40G	5		
20G48G	6		
20G64G	8		
20G80G	10		
24G24G	3	1.25	2.94
24G32G	4		
24G40G	5		
24G48G	6		
24G64G	8		
24G80G	10		

# Self-Lubricating Corner Guide Blocks – Metric



## Product Features

These metric corner guide blocks fully meet the NAAMS standard. The oil-impregnated graphite plugs cover 20-30% of the wear surface, ensuring self-lubrication. They are available with dowel holes.

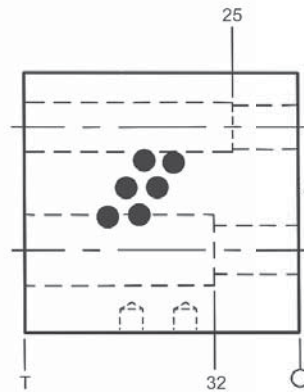
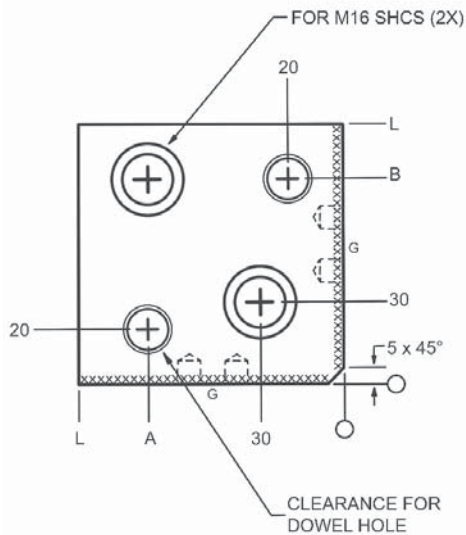

### MATERIALS:

- ◆ High quality carburized steel with oil-impregnated graphite plugs. They are precision ground and hardened to Rc56-62.

### TOLERANCES:

- ◆ Mounting hole locations  $\pm 0.25\text{mm}$
- ◆ Dowel holes  $\pm 0.10\text{mm}$

### MOUNTING SCREWS:

- ◆ M16 S.H.C.S. recommended for mounting

Part Number	NAAMS Code	Thickness T (mm)	Length L (mm)	A (mm)	B (mm)
Q80GD75G	G118007	75	80	55	60
Q80GD100G	G118010	100			
Q80GD125G	G118012	125			
Q95GD75G	G119507	75	95	70	75
Q95GD100G	G119510	100			
Q95GD125G	G119512	125			
Q120GD75G	G111207	75	120	95	100
Q120GD100G	G111210	100			
Q120GD125G	G111212	125			

# Self-Lubricating Center Key & Guide – Metric

## Product Features

The Center Key and Center Key Guide are available in 200 and 300mm lengths and fully meet the NAAMS standard. They come standard with M12 dowel holes for location and are drilled to accommodate M12 S.H.C.S. for mounting.

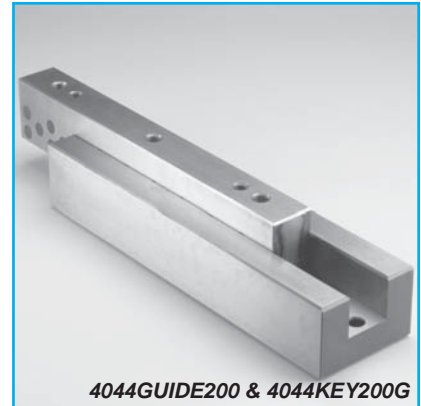

**FIGURE A**  
Center Key Guide

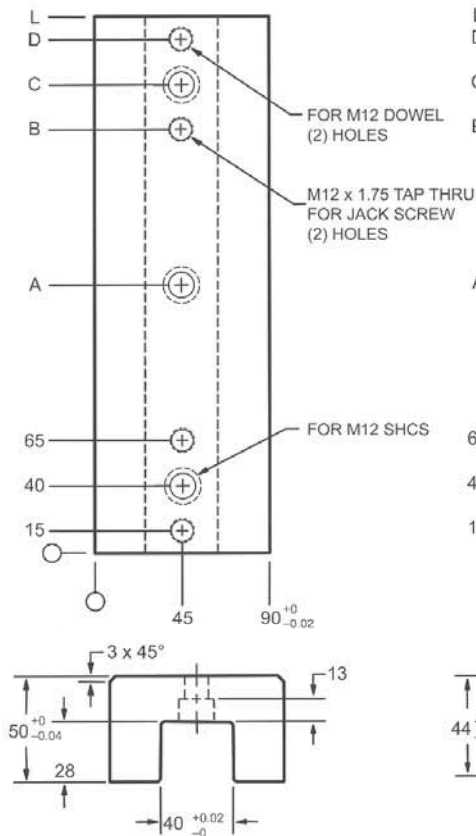

**FIGURE B**  
Center Key

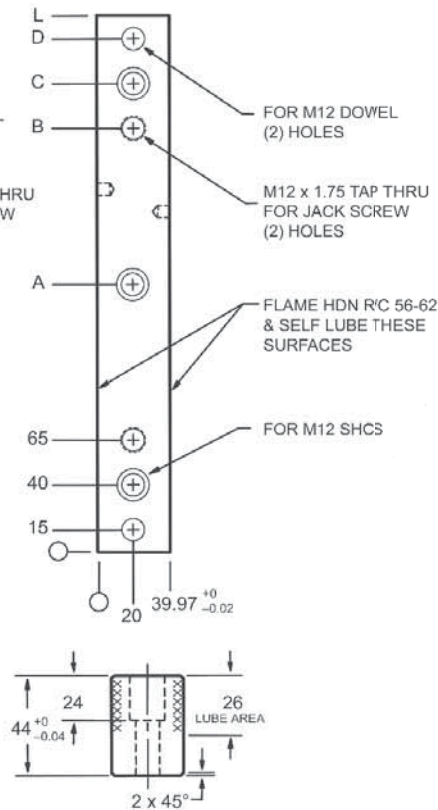

### MATERIALS:

- Center Key Guide is manufactured from high quality carburized steel. The wear surfaces are precision ground and hardened to Rc56-62.
- Center Key is manufactured from high quality carburized steel with oil-impregnated graphite plugs covering 20-30% of the wear surface. The wear surface is precision ground and hardened to Rc56-62. The product is also available as a special in aluminum bronze material.

### TOLERANCES:

- Mounting hole locations  $\pm 0.25$  mm
- Dowel hole locations  $\pm 0.10$  mm

### MOUNTING SCREWS:

- M12 S.H.C.S. are recommended for mounting.

Part Number	Steel NAAMS Code	Bronze NAAMS Code	Length L (mm)	Mounting Hole Qty.	A (mm)	B (mm)	C (mm)	Figure
4044GUIDE200	G419020	N/A	200	2	–	135	160	A
4044GUIDE300	G419030	N/A	300	3	150	235	260	A
4044KEY200G	G424020	–	200	2	–	135	160	B
4044KEY300G	G424030	–	300	3	150	235	260	B
4044KEY200GBRZ	–	G434020	200	2	–	135	160	B
4044KEY300GBRZ	–	G434030	300	3	150	235	260	B

# Self-Lubricating Keeper Plates – Inch



KPSG10408

## Product Features

These self-lubricating Keeper plates are 1-1/4 inch thick and are available in 4- and 5-inch widths and up to 12 inches in length. They are manufactured from hardened steel with oil-impregnated graphite plugs. The Keepers are available with or without mounting holes. The 5-inch width Keepers are also available in a double-sided mounting style.

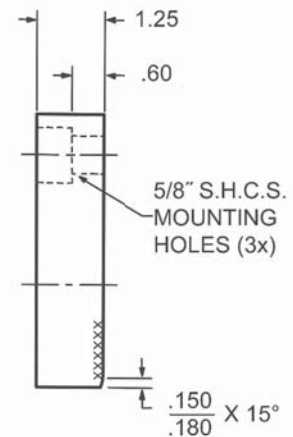
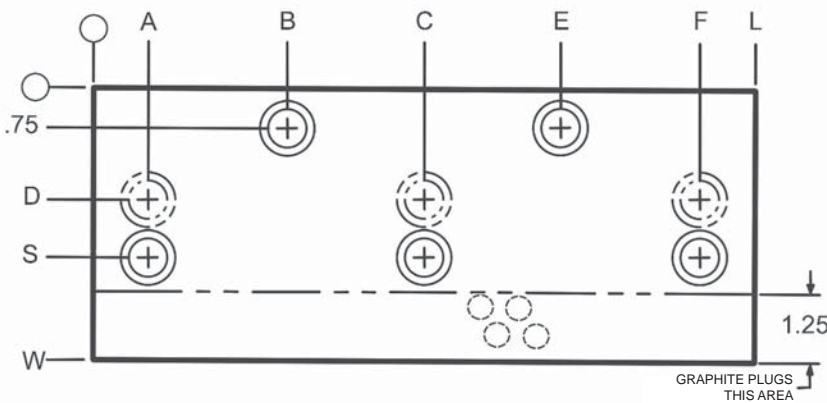

### MATERIALS:

- ◆ High quality carburized steel with oil-impregnated graphite plugs. They are precision ground and hardened to Rc56-62.

### MOUNTING SCREWS:

- ◆ Three 5/8" S.H.C.S. are recommended for mounting. Plate has 11/16" drill through 1" counterbore.

**NOTE:** CHECK ALL SCREW HOLE LOCATIONS. STAGGER KEEPER PLATE AND WEAR PLATES TO AVOID SCREW INTERFERENCE. IF NOT POSSIBLE, THEN SPECIFY AN UNDRILLED KEEPER PLATE (SUFFIX "N").

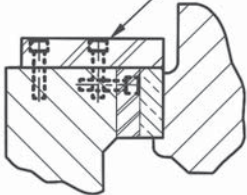

Width W (in)	Length L (in)	Part Number (w/mount'g holes)	Part Number (w/o mount'g holes)	Part Number (double sided)	S (in)	Mounting Hole Location					
						A (in)	B (in)	C (in)	D (in)	E (in)	F (in)
4.00	8.00	KPSG10408	KPSG10408N	KPSG10408D	2.12	1.50	4.00	—	—	—	6.50
	10.00	KPSG10410	KPSG10410N	KPSG10410D			3.25	5.00		6.75	8.50
	12.00	KPSG10412	KPSG10412N	KPSG10412D			3.75	6.00		8.25	10.50
5.00	8.00	KPSG10508	KPSG10508N	KPSG10508D	3.12	1.00	4.00	—	2.25	—	7.00
	10.00	KPSG10510	KPSG10510N	KPSG10510D			3.00	5.00		7.00	9.00
	12.00	KPSG10512	KPSG10512N	KPSG10512D			3.50	6.00		8.50	11.00

# Self-Lubricating Keeper Plates – Metric

## Product Features

These self-lubricating metric Keeper plates are 30mm thick and fully meet the NAAMS standard. They are manufactured from hardened steel with oil-impregnated graphite plugs. The plates are available with or without mounting holes.



**KPSG30-150-200F**

### MATERIALS:

- High quality carburized steel with oil-impregnated graphite plugs. They are precision ground and hardened to Rc56-62.

### MOUNTING SCREWS:

- M16 SDCS recommended for mounting with 17.5mm drill thru in plate.

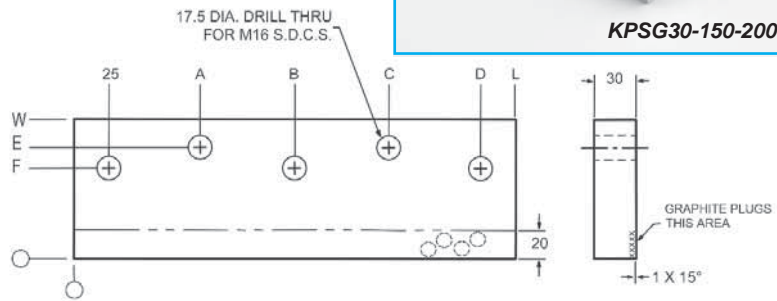

Width W (mm)	Length L (mm)	With Mounting Holes		Without Mounting Holes		Mount'g. Hole Quantity	Mounting Hole Locations					
		Part Number	NAAMS Code	Part Number	NAAMS Code		A (mm)	B (mm)	C (mm)	D (mm)	E (mm)	F (mm)
75	200	KPSG30-75-200F	—	KPSG30-75-200N	—	3	100	—	—	175	55	40
	250	KPSG30-75-250F	—	KPSG30-75-250N	—	3	125	—	—	225		
	315	KPSG30-75-315F	—	KPSG30-75-315N	—	5	90	158	225	290		
	350	KPSG30-75-350F	—	KPSG30-75-350N	—	5	100	175	250	325		
	400	KPSG30-75-400F	—	KPSG30-75-400N	—	5	115	200	285	375		
	450	KPSG30-75-450F	—	KPSG30-75-450N	—	5	125	225	325	425		
100	200	KPSG30-100-200F	R211020	KPSG30-100-200N	R221020	3	100	—	—	175	80	55
	250	KPSG30-100-250F	R211025	KPSG30-100-250N	R221025	4	90	—	160	225		
	315	KPSG30-100-315F	R211031	KPSG30-100-315N	R221031	5	90	158	225	290		
	350	KPSG30-100-350F	R211035	KPSG30-100-350N	R221035	5	100	175	250	325		
	400	KPSG30-100-400F	R211040	KPSG30-100-400N	R221040	5	115	200	285	375		
	450	KPSG30-100-450F	R211045	KPSG30-100-450N	R221045	5	125	225	325	425		
125	200	KPSG30-125-200F	R211220	KPSG30-125-200N	R221220	3	100	—	—	175	105	65
	250	KPSG30-125-250F	R211225	KPSG30-125-250N	R221225	4	90	—	160	225		
	315	KPSG30-125-315F	R211231	KPSG30-125-315N	R221231	5	90	158	225	290		
	350	KPSG30-125-350F	R211235	KPSG30-125-350N	R221235	5	100	175	250	325		
	400	KPSG30-125-400F	R211240	KPSG30-125-400N	R221240	5	115	200	285	375		
	450	KPSG30-125-450F	R211245	KPSG30-125-450N	R221245	5	125	225	325	425		
150	200	KPSG30-150-200F	R211520	KPSG30-150-200N	R221520	3	100	—	—	175	130	65
	250	KPSG30-150-250F	R211525	KPSG30-150-250N	R221525	4	90	—	160	225		
	315	KPSG30-150-315F	R211531	KPSG30-150-315N	R221531	5	90	158	225	290		
	350	KPSG30-150-350F	R211535	KPSG30-150-350N	R221535	5	100	175	250	325		
	400	KPSG30-150-400F	R211540	KPSG30-150-400N	R221540	5	115	200	285	375		
	450	KPSG30-150-450F	R211545	KPSG30-150-450N	R221545	5	125	225	325	425		



# Light Duty K Series Self-Lubricating Keeper Blocks – Inch



## Product Features

These light duty Keeper blocks are manufactured from hardened steel with oil-impregnated graphite plugs covering 20-30% of the wear surface. The Keepers are supplied with mounting holes for 1/2" S.H.C.S. All blocks are marked with the part number for ease of identification.

### FOR 3.0" & 4.0" LENGTHS

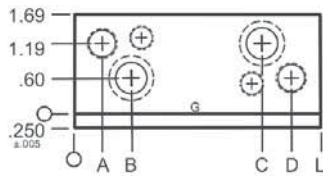

### FOR 5.0" & 6.0" LENGTHS

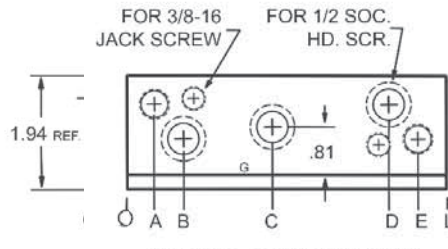

### FOR 8.0" TO 10.0" LENGTHS

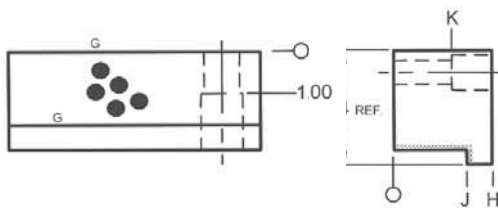
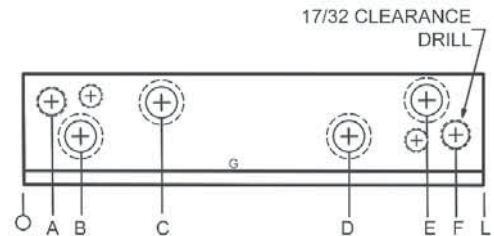

#### MATERIALS:

- ◆ High quality carburized steel with oil-impregnated graphite plugs. They are precision ground and hardened to Rc56-62.

#### TOLERANCES:

- ◆ J Dimension  $\pm 0.001$  in.

#### MOUNTING SCREWS:

- ◆ 1/2" S.H.C.S. recommended for mounting.

# Light Duty K Series Self-Lubricating Keeper Blocks – Inch

GENERAL DIMENSIONS	Length L (in)	Mounting Hole Quantity	Mounting Hole Location					
			A (in)	B (in)	C (in)	D (in)	E (in)	F (in)
	3.00	2	0.50	1.00	2.00	2.50	–	–
	4.00	2			3.00	3.50	–	–
	5.00	3			2.50	4.00	4.50	–
	6.00	3			3.00	5.00	5.50	–
	8.00	4			2.38	5.62	7.00	7.50
	10.00	4			3.50	6.50	9.00	9.50

Part Number	Length L (in)	H (in)	J (in)	K (in)
8K24G	3.00	1.44	1.000	0.94
8K32G	4.00			
8K40G	5.00			
8K48G	6.00			
8K64G	8.00			
8K80G	10.00			
10K24G	3.00	1.69	1.250	1.00
10K32G	4.00			
10K40G	5.00			
10K48G	6.00			
10K64G	8.00			
10K80G	10.00			
12K24G	3.00	1.94	1.500	1.25
12K32G	4.00			
12K40G	5.00			
12K48G	6.00			
12K64G	8.00			
12K80G	10.00			
14K24G	3.00	2.44	1.750	1.25
14K32G	4.00			
14K40G	5.00			
14K48G	6.00			
14K64G	8.00			
14K80G	10.00			

# Medium Duty KM Series Self-Lubricating Keeper Blocks – Inch



8KM24G

## Product Features

These medium duty Keeper blocks are manufactured from hardened steel with oil-impregnated graphite plugs covering 20-30% of the wear surface. The Keepers are supplied with mounting holes for 1/2" S.H.C.S. All blocks are marked with the part number for ease of identification.

### FOR 3.0" LENGTHS

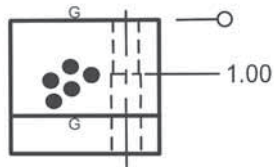

### FOR 4.0" TO 6.0" LENGTHS

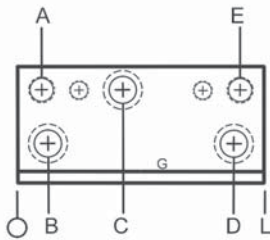

### FOR 8.0" LENGTHS

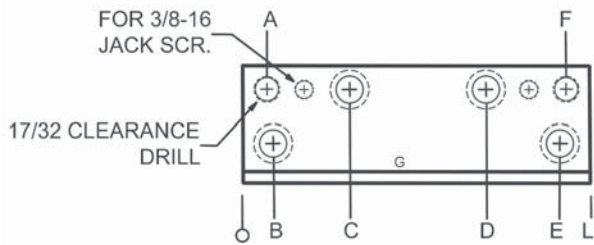

### FOR 10.0" LENGTHS

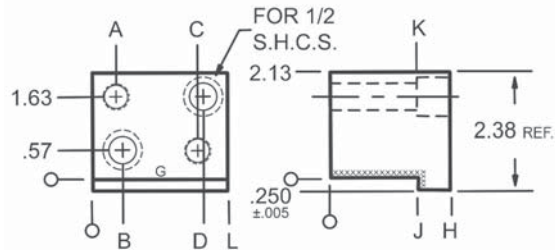
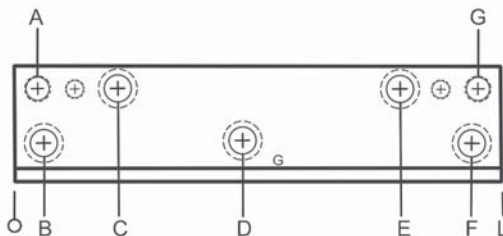

Part Number	Length L (in)	H (in)	J (in)	K (in)
8KM24G	3.00	1.62	1.000	1.00
8KM32G	4.00			
8KM40G	5.00			
8KM48G	6.00			
8KM64G	8.00			
8KM80G	10.00	1.88	1.250	1.25
10KM24G	3.00			
10KM32G	4.00			
10KM40G	5.00			
10KM48G	6.00			
10KM64G	8.00	2.12	1.500	1.50
10KM80G	10.00			
12KM24G	3.00			
12KM32G	4.00			
12KM40G	5.00			
12KM48G	6.00	2.44	1.750	1.25
12KM64G	8.00			
12KM80G	10.00			
14KM24G	3.00			
14KM32G	4.00			
14KM40G	5.00	2.44	1.750	1.25
14KM48G	6.00			
14KM64G	8.00			
14KM80G	10.00			

# Medium Duty KM Series Self-Lubricating Keeper Blocks – Inch

GENERAL DIMENSIONS	Length L (in)	Mounting Hole Quantity	Mounting Hole Location						
			A (in)	B (in)	C (in)	D (in)	E (in)	F (in)	G (in)
	3.00	2	0.50	0.62	2.38	2.50	–	–	–
	4.00	3			2.12	3.38	3.50	–	–
	5.00	3			2.12	4.38	4.50	–	–
	6.00	3			2.12	5.38	5.50	–	–
	8.00	4			2.12	5.88	7.38	7.50	–
	10.00	5			2.12	5.38	7.88	9.38	9.50

Part Number	Length L (in)	H (in)	J (in)	K (in)
16KM24G	3.00	2.69	2.000	1.75
16KM32G	4.00			
16KM40G	5.00			
16KM48G	6.00			
16KM64G	8.00			
16KM80G	10.00			
18KM24G	3.00	2.88	2.250	1.75
18KM32G	4.00			
18KM40G	5.00			
18KM48G	6.00			
18KM64G	8.00			
18KM80G	10.00			
20KM24G	3.00	3.25	2.500	1.75
20KM32G	4.00			
20KM40G	5.00			
20KM48G	6.00			
20KM64G	8.00			
20KM80G	10.00			
22KM24G	3.00	3.38	2.750	1.75
22KM32G	4.00			
22KM40G	5.00			
22KM48G	6.00			
22KM64G	8.00			
22KM80G	10.00			

**MATERIALS:**

- ◆ High quality carburized steel with oil-impregnated graphite plugs. They are precision ground and hardened to Rc56-62.

**TOLERANCES:**

- ◆  $J \pm 0.001$  in.

**MOUNTING SCREWS:**

- ◆ 1/2" S.H.C.S. recommended for mounting

# Heavy Duty KH Series Self-Lubricating Keeper Blocks



## Product Features

These heavy duty Keeper blocks are manufactured from hardened steel with oil-impregnated graphite plugs covering 25% of the wear surface. The Keepers are supplied with mounting holes for 5/8" S.H.C.S. All blocks are marked with the part number for ease of identification.

### FOR 4.0" TO 6.0" LENGTHS

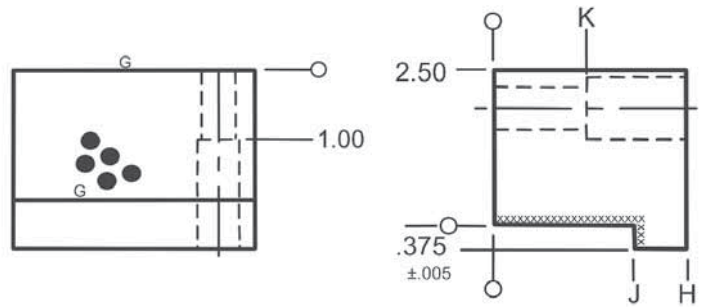
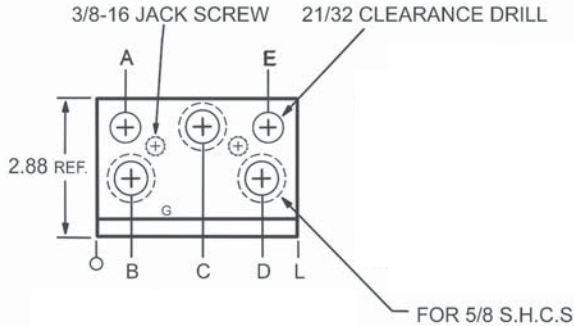

### FOR 8.0" LENGTHS

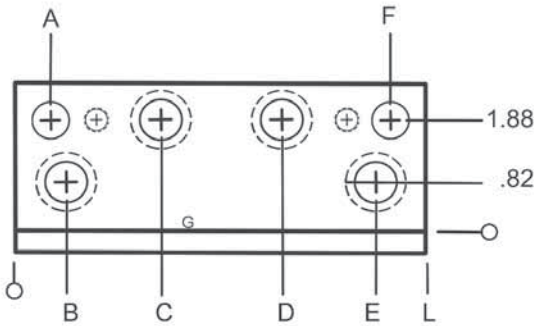

### FOR 10.0" LENGTHS

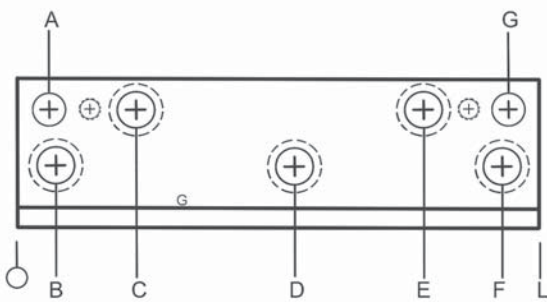

Part Number	Length L (in)	H (in)	J (in)	K (in)
14KH32G	4.00	2.62	1.750	1.50
14KH40G	5.00			
14KH48G	6.00			
14KH64G	8.00			
14KH80G	10.00			
14KH96G	12.00			
16KH32G	4.00	2.88	2.000	1.50
16KH40G	5.00			
16KH48G	6.00			
16KH64G	8.00			
16KH80G	10.00			
16KH96G	12.00			
18KH32G	4.00	3.12	2.250	1.50
18KH40G	5.00			
18KH48G	6.00			
18KH64G	8.00			
18KH80G	10.00			
18KH96G	12.00			

# Heavy Duty KH Series Self-Lubricating Keeper Blocks

GENERAL DIMENSIONS	Length L (in)	Mounting Hole Qty.	Mounting Hole Location						
			A (in)	B (in)	C (in)	D (in)	E (in)	F (in)	G (in)
	4.00	3	0.62	0.75	2.25	3.25	3.38	–	–
	5.00	3				4.25	4.38	–	–
	6.00	3				5.25	5.38	–	–
	8.00	4				5.75	7.25	7.38	–
	10.00	5				5.25	7.75	9.25	9.38
	12.00	5				5.75	9.75	11.25	11.38

Part Number	Length L (in)	H (in)	J (in)	K (in)
20KH32G	4.00	3.38	2.500	2.25
20KH40G	5.00			
20KH48G	6.00			
20KH64G	8.00			
20KH80G	10.00			
20KH96G	12.00			
22KH32G	4.00	3.62	2.750	2.25
22KH40G	5.00			
22KH48G	6.00			
22KH64G	8.00			
22KH80G	10.00			
22KH96G	12.00			
24KH32G	4.00	3.88	3.000	2.25
24KH40G	5.00			
24KH48G	6.00			
24KH64G	8.00			
24KH80G	10.00			
24KH96G	12.00			

**MATERIALS:**

- ◆ High quality carburized steel with oil-impregnated graphite plugs. They are precision ground and hardened to Rc56-62.

**TOLERANCES:**

- ◆ J Dimension            ± 0.001 in.

**MOUNTING SCREWS:**

- ◆ 5/8" S.H.C.S. recommended for mounting

# Self-Lubricating 6mm LIP Keeper Blocks – Metric



## Product Features

These metric Keeper blocks fully meet the NAAMS standard. The oil-impregnated graphite plugs cover 20-30% of the wear surface, ensuring self-lubrication. They are available with dowel holes. For ease of identification, all parts are marked with the part number and NAAMS code.

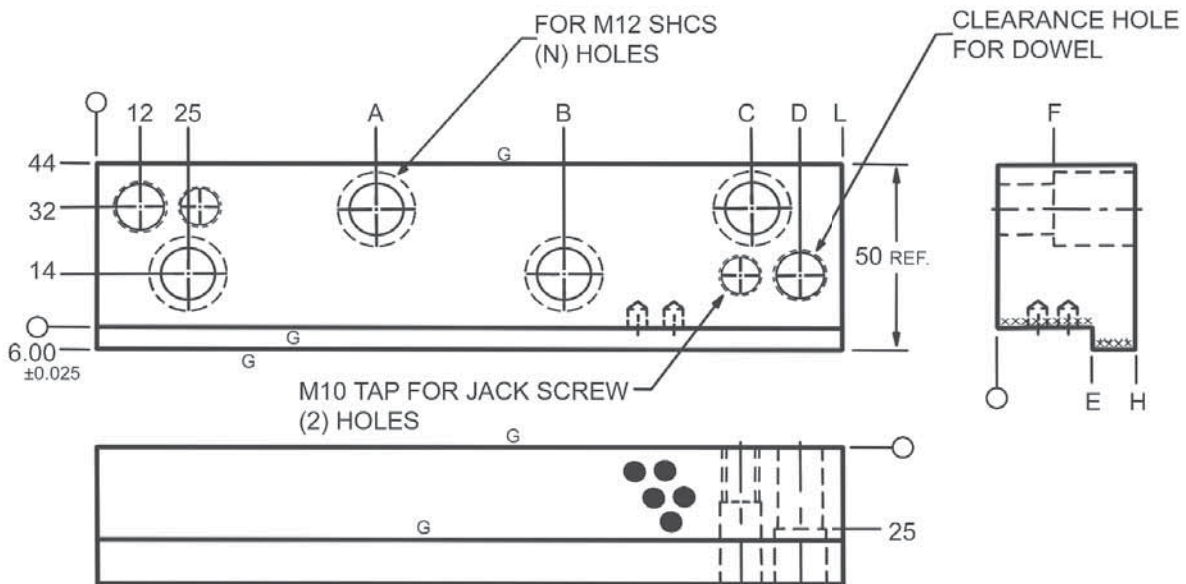

### MATERIALS:

- ◆ High quality carburized steel with oil-impregnated graphite plugs. They are precision ground and hardened to Rc56-62.

### TOLERANCES:

- ◆ Mounting hole locations  $\pm 0.25\text{mm}$
- ◆ Dowel holes  $\pm 0.10\text{mm}$

### MOUNTING SCREWS:

- ◆ M12 S.H.C.S. recommended for mounting



# Self-Lubricating 6mm LIP Keeper Blocks – Metric

Part Number	NAAMS Code	Length L (mm)	Hole Qty.	Mounting Hole Location				E (mm)	F (mm)	H (mm)
				A (mm)	B (mm)	C (mm)	D (mm)			
Q25K75G	R 012507	75	2	–	–	50	63	25.00	15	37
Q25K100G	R 012510	100	2	–	–	75	88			
Q25K125G	R 012512	125	3	–	62.5	100	113			
Q25K150G	R 012515	150	3	–	75.0	125	138			
Q25K175G	R 012517	175	3	–	87.5	150	163			
Q25K200G	R 012520	200	4	75	125.0	175	188			
Q32K75G	R 013207	75	2	–	–	50	63	32.00	15	45
Q32K100G	R 013210	100	2	–	–	75	88			
Q32K125G	R 013212	125	3	–	62.5	100	113			
Q32K150G	R 013215	150	3	–	75.0	125	138			
Q32K175G	R 013217	175	3	–	87.5	150	163			
Q32K200G	R 013220	200	4	75	125.0	175	188			
Q37K75G	R 013707	75	2	–	–	50	63	37.00	30	50
Q37K100G	R 013710	100	2	–	–	75	88			
Q37K125G	R 013712	125	3	–	62.5	100	113			
Q37K150G	R 013715	150	3	–	75.0	125	138			
Q37K175G	R 013717	175	3	–	87.5	150	163			
Q37K200G	R 013720	200	4	75	125.0	175	188			
Q48K75G	R 014807	75	2	–	–	50	63	48.00	30	60
Q48K100G	R 014810	100	2	–	–	75	88			
Q48K125G	R 014812	125	3	–	62.5	100	113			
Q48K150G	R 014815	150	3	–	75.0	125	138			
Q48K175G	R 014817	175	3	–	87.5	150	163			
Q48K200G	R 014820	200	4	75	125.0	175	188			
Q48K250G	R 014825	250	4	95	165.0	225	238			
Q55K75G	R 015507	75	2	–	–	50	63	55.00	30	75
Q55K100G	R 015510	100	2	–	–	75	88			
Q55K125G	R 015512	125	3	–	62.5	100	113			
Q55K150G	R 015515	150	3	–	75.0	125	138			
Q55K175G	R 015517	175	3	–	87.5	150	163			
Q55K200G	R 015520	200	4	75	125.0	175	188			
Q55K250G	R 015525	250	4	95	165.0	225	238			

**NOTE:** Remove "Q" prefix for unfinished dowel holes.

# Self-Lubricating 13mm LIP Keeper Blocks – Metric



## Product Features

These metric Keeper blocks fully meet the NAAMS standard. The oil-impregnated graphite plugs cover 20-30% of the wear surface, ensuring self-lubrication. They are available with dowel holes. For ease of identification, all parts are marked with the part number and NAAMS code.

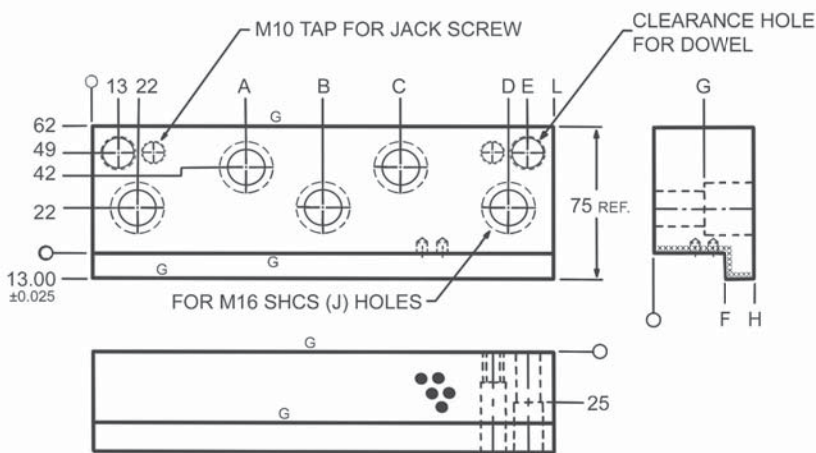

### MATERIALS:

- ◆ High quality carburized steel with oil-impregnated graphite plugs. They are precision ground and hardened to Rc56-62.

### TOLERANCES:

- ◆ Mounting hole locations  $\pm 0.25\text{mm}$
- ◆ Dowel holes  $\pm 0.10\text{mm}$

### MOUNTING SCREWS:

- ◆ M16 S.H.C.S. recommended for mounting.

Part Number	NAAMS Code	Length L (mm)	Hole Qty.	Mounting Hole Location					F (mm)	G (mm)	H (mm)
				A (mm)	B (mm)	C (mm)	D (mm)	E (mm)			
Q35KN100G	R 023510	100	2	–	–	–	78	87	35.00	25	50
Q35KN125G	R 023512	125	3	62.5	–	–	103	112			
Q35KN150G	R 023515	150	3	75.0	–	–	128	137			
Q35KN200G	R 023520	200	4	75.0	–	125	178	187			
Q35KN225G	R 023522	225	5	75.0	112.5	150	203	212			
Q35KN250G	R 023525	250	5	75.0	125.0	175	228	237			
Q35KN300G	R 023530	300	5	75.0	150.0	225	278	287			
Q40KN100G	R 024010	100	2	–	–	–	78	87	40.00	25	60
Q40KN125G	R 024012	125	3	62.5	–	–	103	112			
Q40KN150G	R 024015	150	3	75.0	–	–	128	137			
Q40KN200G	R 024020	200	4	75.0	–	125	178	187			
Q40KN225G	R 024022	225	5	75.0	112.5	150	203	212			
Q40KN250G	R 024025	250	5	75.0	125.0	175	228	237			
Q40KN300G	R 024030	300	5	75.0	150.0	225	278	287			

**NOTE:** Remove "Q" prefix for unfinished dowel holes.

# Self-Lubricating 13mm LIP Keeper Blocks – Metric

Part Number	NAAMS Code	Length L (mm)	Hole Qty.	Mounting Hole Location					F (mm)	G (mm)	H (mm)
				A (mm)	B (mm)	C (mm)	D (mm)	E (mm)			
Q50KN100G	R 025010	100	2	–	–	–	78	87	50.00	30	70
Q50KN125G	R 025012	125	3	62.5	–	–	103	112			
Q50KN150G	R 025015	150	3	75.0	–	–	128	137			
Q50KN200G	R 025020	200	4	75.0	–	125	178	187			
Q50KN225G	R 025022	225	5	75.0	112.5	150	203	212			
Q50KN250G	R 025025	250	5	75.0	125.0	175	228	237			
Q50KN300G	R 025030	300	5	75.0	150.0	225	278	287			
Q55KN100G	R 025510	100	2	–	–	–	78	87	55.00	35	80
Q55KN125G	R 025512	125	3	62.5	–	–	103	112			
Q55KN150G	R 025515	150	3	75.0	–	–	128	137			
Q55KN200G	R 025520	200	4	75.0	–	125	178	187			
Q55KN225G	R 025522	225	5	75.0	112.5	150	203	212			
Q55KN250G	R 025525	250	5	75.0	125.0	175	228	237			
Q55KN300G	R 025530	300	5	75.0	150.0	225	278	287			
Q65KN100G	R 026510	100	2	–	–	–	78	87	65.00	45	90
Q65KN125G	R 026512	125	3	62.5	–	–	103	112			
Q65KN150G	R 026515	150	3	75.0	–	–	128	137			
Q65KN200G	R 026520	200	4	75.0	–	125	178	187			
Q65KN225G	R 026522	225	5	75.0	112.5	150	203	212			
Q65KN250G	R 026525	250	5	75.0	125.0	175	228	237			
Q65KN300G	R 026530	300	5	75.0	150.0	225	278	287			
Q75KN100G	R 027510	100	2	–	–	–	78	87	75.00	45	100
Q75KN125G	R 027512	125	3	62.5	–	–	103	112			
Q75KN150G	R 027515	150	3	75.0	–	–	128	137			
Q75KN200G	R 027520	200	4	75.0	–	125	178	187			
Q75KN225G	R 027522	225	5	75.0	112.5	150	203	212			
Q75KN250G	R 027525	250	5	75.0	125.0	175	228	237			
Q75KN300G	R 027530	300	5	75.0	150.0	225	278	287			
Q95KN100G	R 029510	100	2	–	–	–	78	87	95.00	45	120
Q95KN125G	R 029512	125	3	62.5	–	–	103	112			
Q95KN150G	R 029515	150	3	75.0	–	–	128	137			
Q95KN200G	R 029520	200	4	75.0	–	125	178	187			
Q95KN225G	R 029522	225	5	75.0	112.5	150	203	212			
Q95KN250G	R 029525	250	5	75.0	125.0	175	228	237			
Q95KN300G	R 029530	300	5	75.0	150.0	225	278	287			

**NOTE:** Remove "Q" prefix for unfinished dowel holes.

# Self-Lubricating Cam Dwell Wearplates

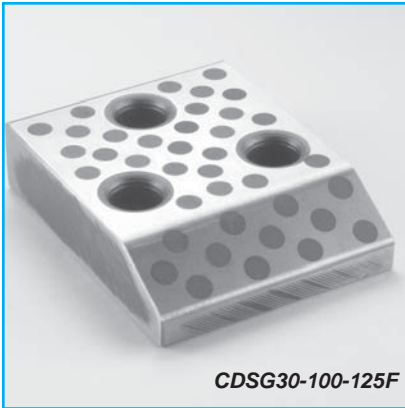

## Product Features

The cam dwell series of wearplates are available in 30, 45 and 60mm thicknesses and in widths of 100, 125 and 160mm. They are available in plain steel and self-lubricating versions and fully meet the NAAMS standard. For ease of identification, all plates are marked with the part number and NAAMS code.

### MATERIALS:

- ◆ Steel plates are manufactured from high quality carburized steel. They are precision ground and hardened to Rc56-62. They are available with or without oil-impregnated graphite plugs. When supplied with graphite plugs, the plugs cover 20-30% of the wear surface and the plates are self-lubricating.
- ◆ Bronze plates are self-lubricating and manufactured from aluminum bronze material with oil-impregnated graphite plugs covering 20-30% of the wear surface.

### TOLERANCES:

- ◆ Thickness  $\pm 0.05$  mm
- ◆ Width  $\pm 0.05$  mm
- ◆ Unless otherwise noted  $\pm 0.25$  mm

### MOUNTING SCREWS:

- ◆ 3-M12 S.H.C.S. are recommended for mounting. 14mm drill thru, 20mm counterbore in plate.

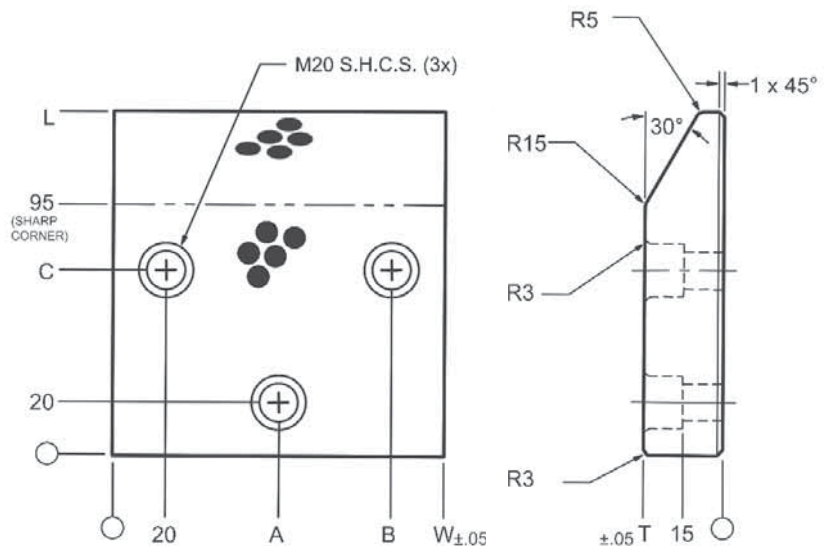

Steel Plain		Steel Self-Lubricating		Bronze Self-Lubricating		T (mm)	W (mm)	L (mm)	A (mm)	B (mm)	C (mm)
Part Number	NAAMS Code	Part Number	NAAMS Code	Part Number	NAAMS Code						
CDSX30100125F	W 211210	CDSG30100125F	W 111210	CDYG30100125F	W 311210	30	100	125	50.0	80	70
CDSX30125125F	W 211212	CDSG30125125F	W 111212	CDYG30125125F	W 311212		125		62.5	105	
CDSX30160125F	W 211216	CDSG30160125F	W 111216	CDYG30160125F	W 311216		160		80.0	140	
CDSX45100150F	W 211510	CDSG45100150F	W 111510	CDYG45100150F	W 311510	45	100	150	50.0	80	65
CDSX45125150F	W 211512	CDSG45125150F	W 111512	CDYG45125150F	W 311512		125		62.5	105	
CDSX45160150F	W 211516	CDSG45160150F	W 111516	CDYG45160150F	W 311516		160		80.0	140	
CDSX60100170F	W 211710	CDSG60100170F	W 111710	CDYG60100170F	W 311710	60	100	170	50.0	80	65
CDSX60125170F	W 211712	CDSG60125170F	W 111712	CDYG60125170F	W 311712		125		62.5	105	
CDSX60160170F	W 211716	CDSG60160170F	W 111716	CDYG60160170F	W 311716		160		80.0	140	

# Stop Blocks – Inch

## Product Features

These stop blocks are precision machined from 1018 material. Additionally, the blocks are inspected to provide uniform quality and dimensions. The length dimension is .060" oversize.

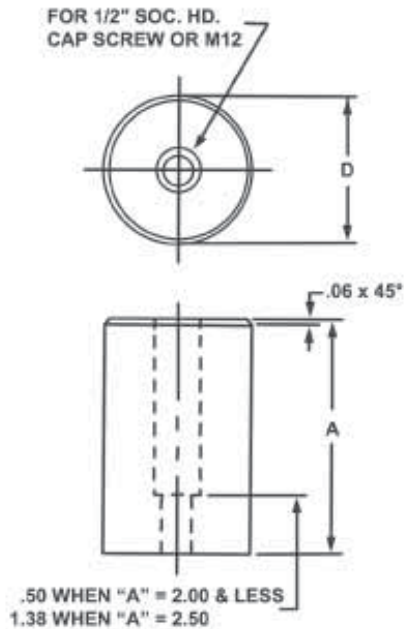

Part Number	Diameter D (in)	Length A (in)
20-150CSB	2.00	1.50
20-200CSB	2.00	2.00
20-250CSB		2.50
20-300CSB	2.00	3.00
20-350CSB		3.50
20-400CSB	2.00	4.00
20-425CSB		4.25
20-475CSB	2.00	4.75
20-525CSB		5.25
20-550CSB	2.00	5.50
20-600CSB		6.00
20-650CSB	2.50	6.50
25-150CSB		1.50
25-200CSB	2.50	2.00
25-250CSB		2.50
25-300CSB	2.50	3.00
25-350CSB		3.50
25-400CSB	2.50	4.00
25-425CSB		4.25
25-475CSB	2.50	4.75
25-525CSB		5.25
25-550CSB	2.50	5.50
25-600CSB		6.00
25-650CSB	2.50	6.50

# Pad Retainers – Locking Inch, Standard Mount



## Product Features

Pad retainers are manufactured from 1144 steel and hardened to 28-34 Rockwell C-scale. They are machined to precise tolerances in order to retain the pad and assure parallelism during use. The NP Series is also available, by special order, that offers three prongs as opposed to knurl.

PART NO.	Diam.		Length	L2 (in)	L3 (in)	L4 (in)	S1 (in)	S2 (in)
	D1 (in)	D2 (in)						
100-100	1.00	.75	1.00	1.00	.38	1.00	5/8 – 18	5/16 – 18
100-125			1.25					
100-150			1.50					
100-175			1.75					
100-200			2.00					
100-225			2.25					
100-250			2.50					
100-275			2.75					
100-300			3.00					
100-325			3.25					
100-350			3.50					
106-100	1.06	.81	1.00	1.00	.375	1.00	5/8 - 18	5/16 - 18
106-125			1.25					
106-150			1.50					
106-175			1.75					
106-200			2.00					
106-225			2.25					
106-250			2.50					
106-275			2.75					
106-300			3.00					
106-325			3.25					
106-350			3.50					
125-100	1.25	1.00	1.00	1.12	.50	1.00	3/4 – 16	3/8 – 16
125-125			1.25					
125-150			1.50					
125-175			1.75					
125-200			2.00					
125-225			2.25					
125-250			2.50					
125-275			2.75					
125-300			3.00					
125-325			3.25					
125-350			3.50					
125-375			3.75					
125-400			4.00					
125-450			4.50					
125-500			5.00					
125-550			5.50					
125-600	6.00							
162-100	1.62	1.25	1.00	1.12	.50	1.25	7/8 – 14	1/2 – 13
162-125			1.25					
162-150			1.50					
162-175			1.75					
162-200			2.00					
162-225			2.25					
162-250			2.50					
162-275			2.75					
162-300			3.00					
162-325			3.25					
162-350			3.50					
162-375			3.75					
162-400			4.00					
162-450			4.50					
162-500	5.00							
162-550	5.50							
162-600	6.00							

# Pad Retainers – Locking Inch, Standard Mount

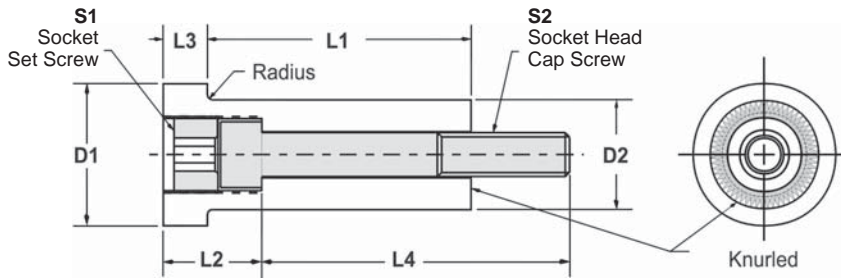

### ASSEMBLY INCLUDES:

- Retainer Body
- Socket Head Cap Screws
- Socket Set Screw

PART NO.	Diam.		Length L1 (in)	L2 (in)	L3 (in)	L4 (in)	S1 (in)	S2 (in)
	D1 (in)	D2 (in)						
162-400	1.62	1.25	4.00	1.12	.50	4.25	7/8 – 14	1/2 – 13
162-450			4.50			4.75		
162-500			5.00			5.25		
162-550			5.50			6.00		
162-600			6.00			6.50		
187-125	1.87	1.50	1.25	1.25	.50	1.50	1-1/8 - 12	5/8 - 11
187-150			1.50			1.75		
187-175			1.75			2.00		
187-200			2.00			2.25		
187-225			2.25			2.50		
187-250			2.50			2.75		
187-275			2.75			3.00		
187-300			3.00			3.25		
187-325			3.25			3.50		
187-350			3.50			3.75		
187-375			3.75			4.00		
187-400			4.00			4.25		
187-450			4.50			5.00		
187-500			5.00			5.50		
187-550			5.50			6.00		
187-600	6.00	6.50						
200-150	2.00	1.62	1.50	1.38	.50	2.00	1-1/4 – 12	3/4 – 10
200-175			1.75			2.25		
200-200			2.00			2.50		
200-225			2.25			2.75		
200-250			2.50			3.00		
200-275			2.75			3.25		
200-300			3.00			3.50		
200-325			3.25			3.75		
200-350			3.50			4.00		
200-375			3.75			4.25		
200-400			4.00			4.50		
200-450			4.50			5.00		
200-500			5.00			5.50		
200-550			5.50			6.00		
200-600			6.00			6.50		

PART NO.	RADIUS (in)	LOAD RATING lbs.
100-XXX	.03	1,500
106-XXX	.03	1,500
125-XXX	.03	3,000
162-XXX	.06	5,000
187-XXX	.06	7,500
200-XXX	.06	10,000



# Pad Retainers – Locking Inch, Standard Mount with Flats



## Product Features

Pad retainers are manufactured from 1144 steel and hardened to 28-34 Rockwell C-scale. They are machined to precise tolerances in order to retain the pad and assure parallelism during use. The NP Series is also available, by special order, that offers three prongs as opposed to knurl.

PART NO.	Diam.		Length	L2 (in)	L3 (in)	L4 (in)	S1 (in)	S2 (in)	
	D1 (in)	D2 (in)							
100-100F	1.00	.75	1.00	1.00	.38	1.00	5/8 – 18	5/16 – 18	
100-125F			1.25			1.25			
100-150F			1.50			1.50			
100-175F			1.75			1.75			
100-200F			2.00			2.00			
100-225F			2.25			2.25			
100-250F			2.50			2.50			
100-275F			2.75			2.75			
100-300F			3.00			3.00			
100-325F			3.25			3.25			
100-350F			3.50			3.50			
106-100F			1.06			.81			1.00
106-125F	1.25	1.25							
106-150F	1.50	1.50							
106-175F	1.75	1.75							
106-200F	2.00	2.00							
106-225F	2.25	2.25							
106-250F	2.50	2.50							
106-275F	2.75	2.75							
106-300F	3.00	3.00							
106-325F	3.25	3.25							
106-350F	3.50	3.50							
125-100F	1.25	1.00		1.00	1.12		.50	3.00	3/4 – 16
125-125F			1.25	1.25					
125-150F			1.50	1.50					
125-175F			1.75	1.75					
125-200F			2.00	2.00					
125-225F			2.25	2.25					
125-250F			2.50	2.50					
125-275F			2.75	2.75					
125-300F			3.00	3.00					
125-325F			3.25	3.25					
125-350F			3.50	3.50					
125-375F			3.75	3.75					
125-400F			4.00	4.00					
125-450F			4.50	4.50					
125-500F			5.00	5.00					
125-550F			5.50	5.50					
125-600F	6.00	6.00							
162-100F	1.62	1.25	1.00	1.12	.50	3.00	7/8 – 14	1/2 – 13	
162-125F			1.25						1.25
162-150F			1.50						1.50
162-175F			1.75						1.75
162-200F			2.00						2.00
162-225F			2.25						2.25
162-250F			2.50						2.50
162-275F			2.75						2.75
162-300F			3.00						3.00
162-325F			3.25						3.25
162-350F			3.50						3.50
162-375F			3.75						3.75
162-400F			4.00						4.00
162-450F			4.50						4.50
162-500F	5.00	5.00							
162-550F	5.50	5.50							
162-600F	6.00	6.00							

# Pad Retainers – Locking Inch, Standard Mount with Flats

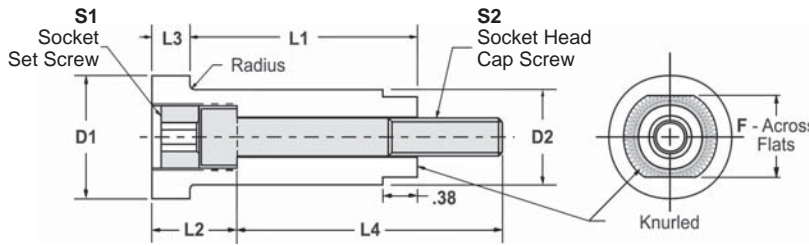

### ASSEMBLY INCLUDES:

- Retainer Body
- Socket Head Cap Screws
- Socket Set Screw

PART NO.	Diam. D1 (in)	Diam. ± .005 D2 (in)	Length L1 (in)	L2 (in)	L3 (in)	L4 (in)	S1 (in)	S2 (in)
162-400F	1.62	1.25	4.00	1.12	.50	4.25	7/8 – 14	1/2 – 13
162-450F			4.50			4.75		
162-500F			5.00			5.25		
162-550F			5.50			6.00		
162-600F			6.00			6.50		
187-125F	1.87	1.50	1.25	1.25	.50	1.50	1-1/8 - 12	5/8 – 11
187-150F			1.50			1.75		
187-175F			1.75			2.00		
187-200F			2.00			2.25		
187-225F			2.25			2.50		
187-250F			2.50			2.75		
187-275F			2.75			3.00		
187-300F			3.00			3.25		
187-325F			3.25			3.50		
187-350F			3.50			3.75		
187-375F			3.75			4.00		
187-400F			4.00			4.25		
187-450F			4.50			5.00		
187-500F			5.00			5.50		
187-550F			5.50			6.00		
187-600F	6.00	6.50						
200-150F	2.00	1.62	1.50	1.38	.50	2.00	1-1/4 – 12	3/4 – 10
200-175F			1.75			2.25		
200-200F			2.00			2.50		
200-225F			2.25			2.75		
200-250F			2.50			3.00		
200-275F			2.75			3.25		
200-300F			3.00			3.50		
200-325F			3.25			3.75		
200-350F			3.50			4.00		
200-375F			3.75			4.25		
200-400F			4.00			4.50		
200-450F			4.50			5.00		
200-500F			5.00			5.50		
200-550F			5.50			6.00		
200-600F			6.00			6.50		

PART NO.	F (in)	RADIUS (in)	LOAD RATING lbs.
100-XXX	.625	.03	1,500
106-XXX	.690	.03	1,500
125-XXX	.875	.03	3,000
162-XXX	1.125	.06	5,000
187-XXX	1.250	.06	7,500
200-XXX	1.375	.06	10,000

# Pad Retainers – Locking Inch, Standard Mount with Flats



## Product Features

Pad retainers are manufactured from 1144 steel and hardened to 28-34 Rockwell C-scale. They are machined to precise tolerances in order to retain the pad and assure parallelism during use.

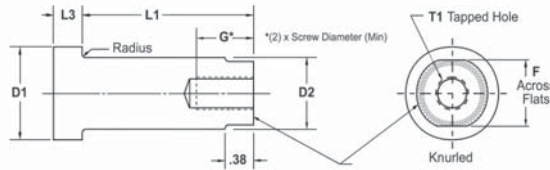

PART NO.	F (in)	RADIUS (in)	LOAD RATING lbs.
100-XXXR	.625	.03	1,500
106-XXXR	.690	.03	1,500
125-XXXR	.875	.03	3,000
162-XXXR	1.125	.06	5,000
187-XXXR	1.250	.06	7,500
200-XXXR	1.375	.06	10,000

PART NO.	Diam. ± .005		Length	G (in)	L3 (in)	T1 (in)					
	D1 (in)	D2 (in)									
100-100R	1.00	.75	1.00	.625	.38	5/16 - 18					
100-125R			1.25								
100-150R			1.50								
100-175R			1.75								
100-200R			2.00								
100-225R			2.25								
100-250R			2.50								
100-275R			2.75								
100-300R			3.00								
100-350R			3.50								
100-375R			3.75								
100-400R			4.00								
100-450R			4.50								
100-500R			5.00								
100-550R			5.50								
100-600R			6.00								
106-100R	1.06	.81	1.00	.625	.38	5/16 - 18					
106-125R			1.25								
106-150R			1.50								
106-175R			1.75								
106-200R			2.00								
106-225R			2.25								
106-250R			2.50								
106-275R			2.75								
106-300R			3.00								
106-325R			3.25								
106-350R			3.50								
125-100R			1.25				1.00	1.00	.750	.50	3/8 - 16
125-125R								1.25			
125-150R								1.50			
125-175R								1.75			
125-200R								2.00			
125-225R	2.25										
125-250R	2.50										
125-275R	2.75										
125-300R	3.00										
125-325R	3.25										
125-350R	3.50										
125-375R	3.75										
125-400R	4.00										
125-450R	4.50										
125-500R	5.00										
125-550R	5.50										
125-600R	6.00										

PART NO.	Diam. ± .005		Length	G (in)	L3 (in)	T1 (in)
	D1 (in)	D2 (in)				
100-125R	1.62	1.25	1.25	1.000	.50	1/2 - 13
162-150R			1.50			
162-175R			1.75			
162-200R			2.00			
162-225R			2.25			
162-250R			2.50			
162-275R			2.75			
162-300R			3.00			
162-325R			3.25			
162-350R			3.50			
162-375R			3.75			
162-400R			4.00			
162-450R			4.50			
162-500R			5.00			
162-550R			5.50			
162-600R			6.00			
187-150R	1.87	1.50	1.50	1.250	.50	5/8 - 11
187-175R			1.75			
187-200R			2.00			
187-225R			2.25			
187-250R			2.50			
187-275R			2.75			
187-300R			3.00			
187-325R			3.25			
187-350R			3.50			
187-375R			3.75			
187-400R			4.00			
187-450R			4.50			
187-500R			5.00			
187-550R			5.50			
187-600R			6.00			
200-175R			2.00			
200-200R	2.00					
200-225R	2.25					
200-250R	2.50					
200-275R	2.75					
200-300R	3.00					
200-325R	3.25					
200-350R	3.50					
200-375R	3.75					
200-400R	4.00					
200-450R	4.50					
200-500R	5.00					
200-550R	5.50					
200-600R	6.00					

# Pad Retainers – Standard Mount – Metric

## Product Features

These pad retainers are manufactured from 1144 steel and hardened to 28-34 Rockwell C-scale. They are machined to precise tolerances in order to retain the pad and assure parallelism during use.



NR50-50

PART NUMBER	D1	D2	L2	L3	S1	S2	LOAD RATING
NR50	50	40	35	15	M27 x 2	M16 x 2.0	192kN
NR70	70	60	40	15	M36 x 3	M20 x 2.5	299kN

PART NUMBER	Diam. D2 (mm)	Length L1 (mm)	Diam. D1 (mm)	Length L4 (mm)
NR50-30	40	30	50	40
NR50-40		40		45
NR50-45		45		50
NR50-50		50		55
NR50-60		60		65
NR50-65		65		70
NR50-70		70		75
NR50-75		75		75
NR50-90		90		100
NR50-100		100		110
NR50-115		115		120
NR50-130		130		140
NR50-140		140		150
NR50-160		160		170
NR70-40	60	40	70	45
NR70-45		45		50
NR70-50		50		55
NR70-60		60		65
NR70-65		65		70
NR70-70		70		75
NR70-75		75		75
NR70-90		90		100
NR70-100		100		110
NR70-115		115		120
NR70-130		130		140
NR70-140		140		150
NR70-160		160		170

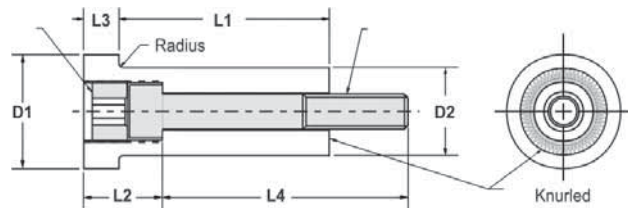

# Pad Retainers – Reverse Mount – Metric



## Product Features

These pad retainers are manufactured from 1144 steel and hardened to 28-34 Rockwell C-scale. They are machined to precise tolerances in order to retain the pad and assure parallelism during use.

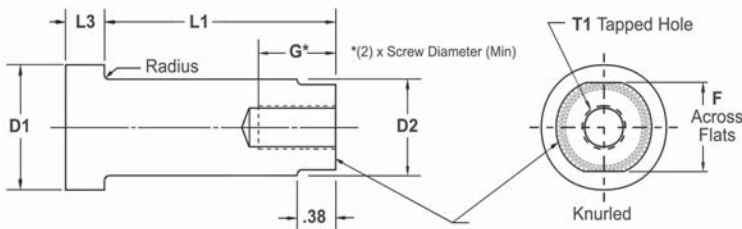

PART NUMBER	D1	D2	F	LOAD L3	RATING
NR50	50	40	33.65	15	192kN
NR70	70	60	53.70	15	299kN

PART NUMBER	Diam. D2 (mm)	Length L1 (mm)	Diam. D1 (mm)	T1 (mm)			
NR50-30R	40	30	50	M16 x 2.0			
NR50-40R		40					
NR50-45R		45					
NR50-50R		50					
NR50-60R		60					
NR50-65R		65					
NR50-70R		70					
NR50-75R		75					
NR50-90R		90					
NR50-100R		100					
NR50-115R		115					
NR50-130R		130					
NR50-140R		140					
NR50-160R		160					
NR70-40R		60			40	70	M20 x 2.5
NR70-45R					45		
NR70-50R	50						
NR70-60R	60						
NR70-65R	65						
NR70-70R	70						
NR70-75R	75						
NR70-90R	90						
NR70-100R	100						
NR70-115R	115						
NR70-130R	130						
NR70-140R	140						
NR70-160R	160						

# WEAR PRODUCTS

## The IEM Value Proposition

- I. **IEM** is recognized as the leader in manufacturing quality die components to the global parts forming industry. Our reputation has been built by satisfying customer needs, and we are very strong in the automotive and appliance industries.
- II. **IEM** offers outstanding delivery on a consistent basis. Choosing us as a supplier means that our customers have a competitive advantage in delivering their products to the market.
- III. **IEM** has complex machining capabilities on die components at several facilities. With extensive machining capabilities in the USA and China, we have taken the lead role in creating and bringing new products to customers and helping them find solutions that improve their operations.
- IV. **IEM's** vast breadth of products assures innovative solutions. We strive to address customer problems by utilizing our research and development department as well as other technical professionals.
- V. **IEM** has a technically trained sales force and distributor channels with Engineering support. Sales, Marketing and Engineering professionals are available to support our product lines.

- **Competitive Prices**
- **Reliability and Performance**

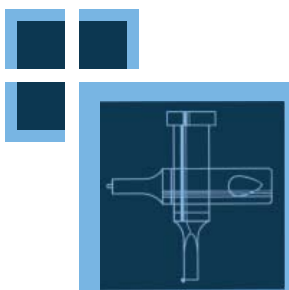
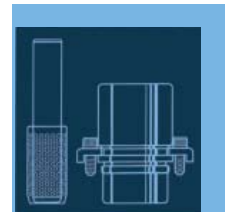

**...A LEADING MANUFACTURER  
AND INNOVATOR OF DIE  
COMPONENTS SUPPLIED  
GLOBALLY TO THE METAL  
FORMING INDUSTRY...**

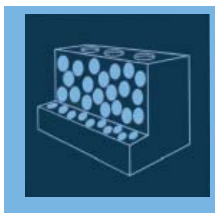

- **High Quality Design & Construction**
- **Outstanding Service & Support**



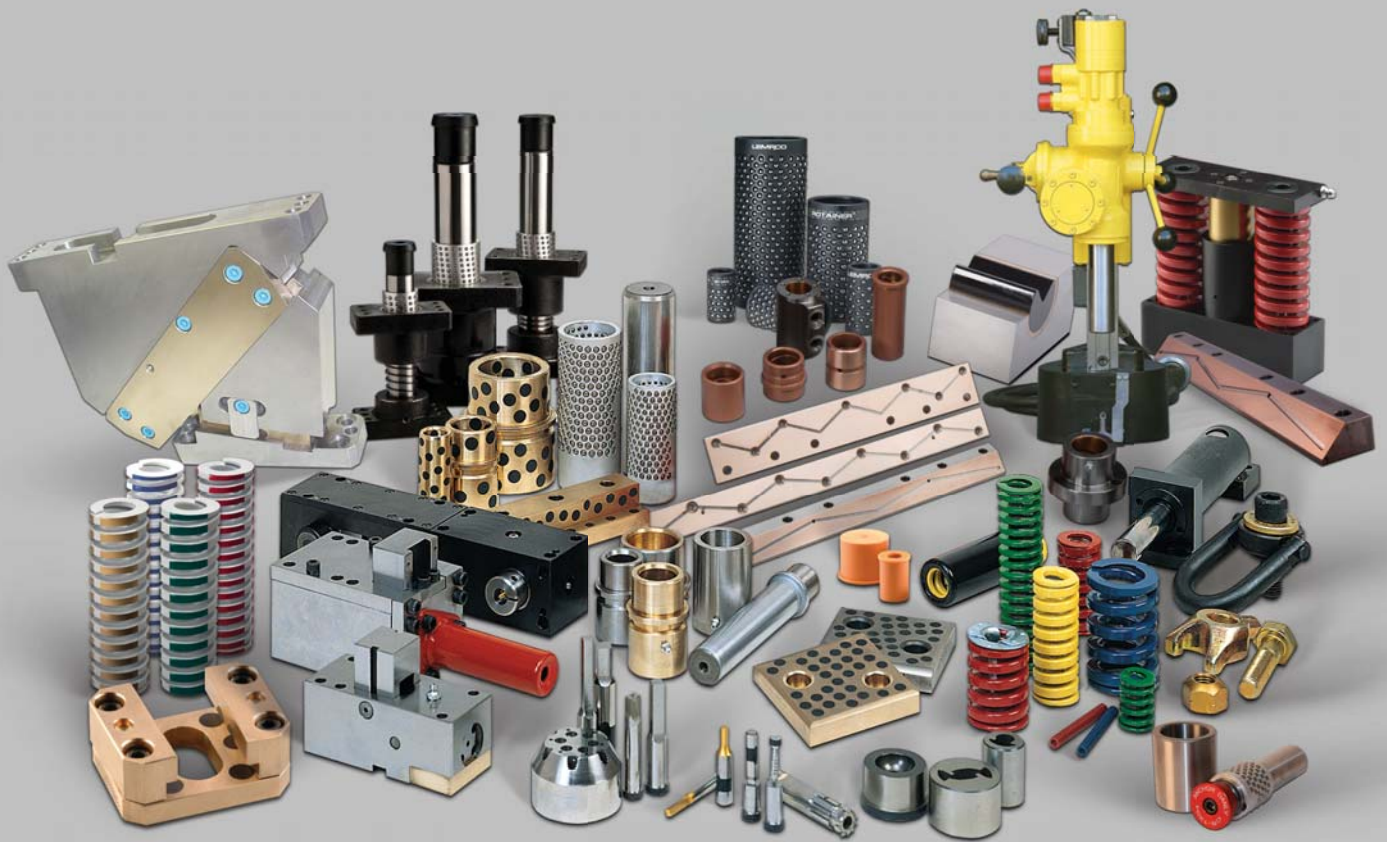

## WEAR PRODUCTS

# IEM<sup>®</sup>

Anchor Lamina America, Inc.

[www.danly.com](http://www.danly.com)

[info@anchorlamina.com](mailto:info@anchorlamina.com)

**WITHIN THE USA & CANADA**

**CALL: 800-652-6462**

**FAX: 800-406-4410**

**OUTSIDE THE USA & CANADA**

**CALL: 001-248-489-9122**

**FAX: 001-248-553-6842**

**Distributed by:**



Registered  
to ISO 9001



Registered  
to ISO 14001