

FasTie[®] Quick Ejector Tie-In System

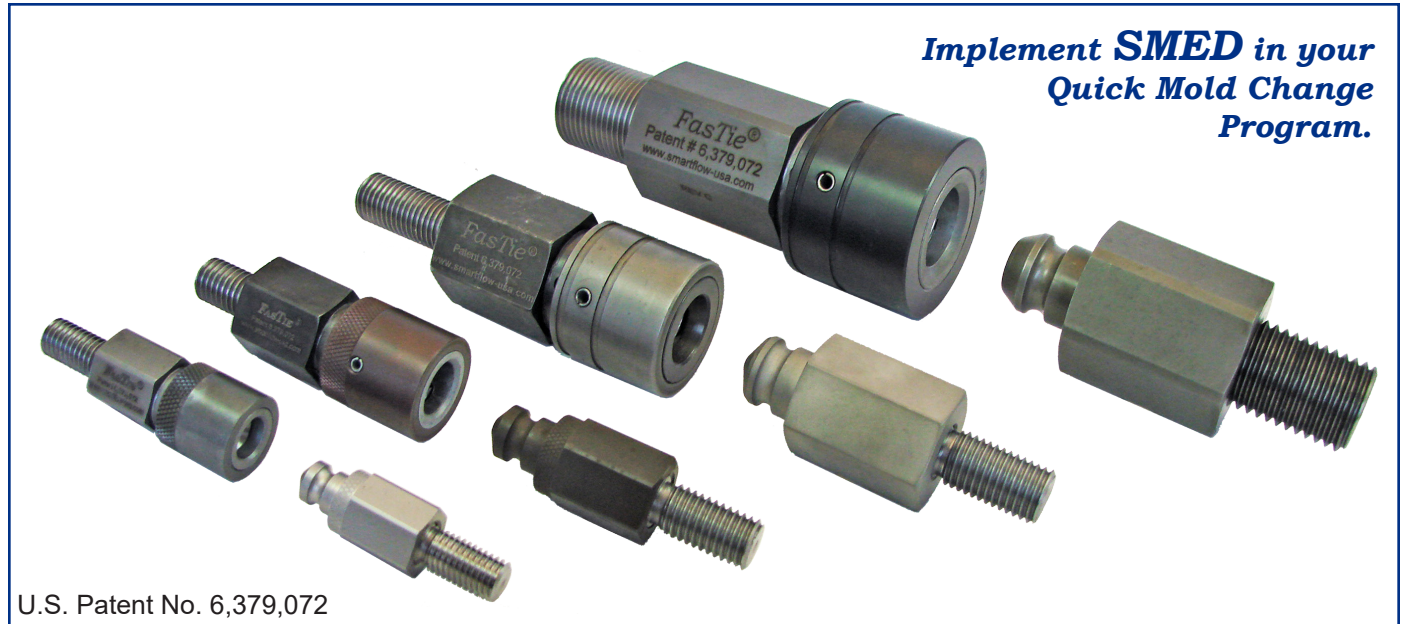

Description & Use

In an injection molding press, the **FasTie** system quickly “ties-in” the mold ejector plate to the press ejection system, dramatically reducing mold change time. The greatest savings are realized in presses where space is limited and the ejector system is difficult to tie in using solid knockout bars.

The **FasTie** coupler may be permanently mounted to the press ejector plate. The quick-connect locking mechanism in the coupler snaps mechanically onto the mold-mounted pull stud during mold installation.

To release the knockouts, apply shop air to the coupler. The coupler opens to release the pull stud, disconnecting the press and mold ejector plates. The coupler remains in the open position, ready for a new mold to be set.

For multiple knockout locations, an air manifold is recommended to release all couplers simultaneously. See inside catalog pages for installation examples.

The FasTie couplers and pull studs are available in 4 sizes to suit various press sizes: 1", 1-3/8", 2" and 3".

Mounting accessories such as center adapters and knockout bars are available to facilitate installation without additional machining to presses or injection molds.

Features & Benefits

- ◆ **FasTie** installs easily into existing tapped holes, no additional machining is required.
- ◆ **FasTie** reduces mold setting time by quickly uncoupling without loose parts to stow.
- ◆ **FasTie** remains coupled during mold cycling for increased “tie-in” reliability and reduced wear.
- ◆ **SpeedBar[®]** adjustable knockout bar changes length quickly without tools [$\pm 1/2"$ (12.7mm) from nominal in .006" (.15mm) increments].*
- ◆ **SpeedBar** saves molders time and cost of machining individual knockout bars to fit different molds.*

*1-inch only

Ask us about custom-machined ejector bar lengths or thread sizes to suit your application.

SMARTFLOW® FasTie® Installation Examples

Typical Application - Couplers on Press Ejector Plate

(Recommended for most injection molding applications)

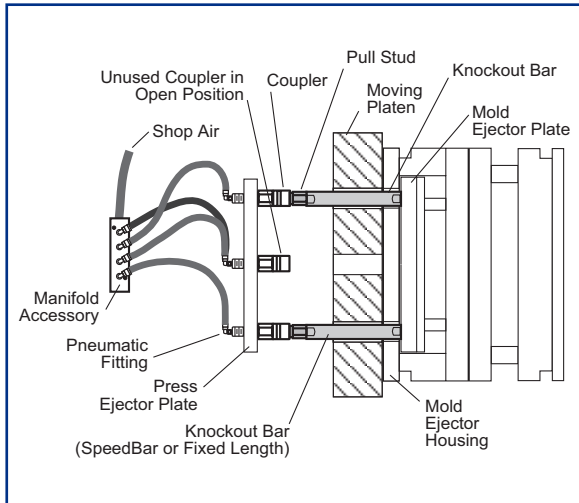

This setup is designed for custom molders using a variety of injection molds with different knockout patterns and ejector strokes.

Couplers are installed on the Press Ejector Plate. Pull Studs are placed at the end of the mold-mounted knockout bars for easy removal. Molds are changed quickly without accessing the back of the Press Ejector Plate.

For example, a press with 4 knockout positions may be running molds using only the horizontal positions, but the next mold may need the 2 vertical knockout positions. Ejector housing shown is 1.062" thick.

Air Manifold supplies air to each coupler for simultaneous release.

Parts List	
Qty	Part
2 or 4	FasTie Pull Stud
2 or 4	FasTie Coupler
2 or 4	Finished Bar Fixed-Length Knockout
1	Air Manifold with tubing

Animated Installation Examples appear on



Search for "burgerandbrowneng" or scan QR code



Ask us about custom-machined ejector bar lengths or thread sizes to suit your application.

Alternate Application - Couplers and Center Adapters on Press Ejector Plate

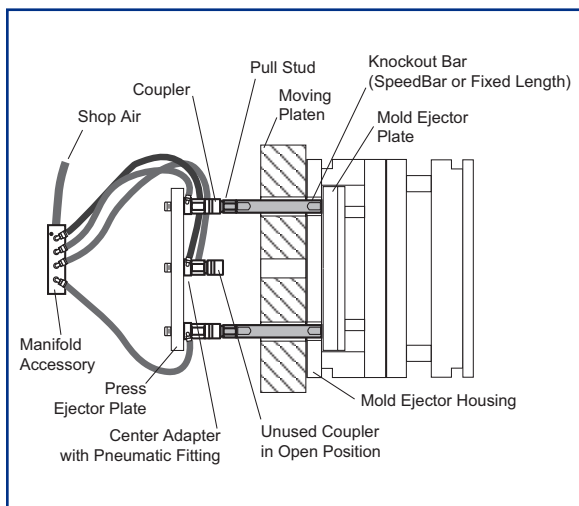

This setup is used where there is limited access to the back of the Press Ejector Plate. Custom molders using smaller presses will benefit from this application.

Couplers and Center Adapters are installed on the Press Ejector Plate. Pull Studs are placed at the end of the mold-mounted knockout bars for easy removal. Molds are changed quickly without accessing the back of the Press Ejector Plate.

For example, a press with 4 knockout positions may be running molds using only the horizontal positions, but the next mold may need the 2 vertical knockout positions. Ejector housing shown is 1.062" thick.

Air Manifold supplies air to the mold side of the Press Ejector Plate with the use of adapters.

Parts List	
Qty	Part
2 or 4	FasTie Pull Stud
2 or 4	FasTie Coupler
2 or 4	Center Adapter
2 or 4	Finished Bar Fixed-Length Knockout
1	Air Manifold with tubing

SMARTFLOW® FasTie® Installation Examples

Center Knockout Application - Coupler in Center Ejector Position

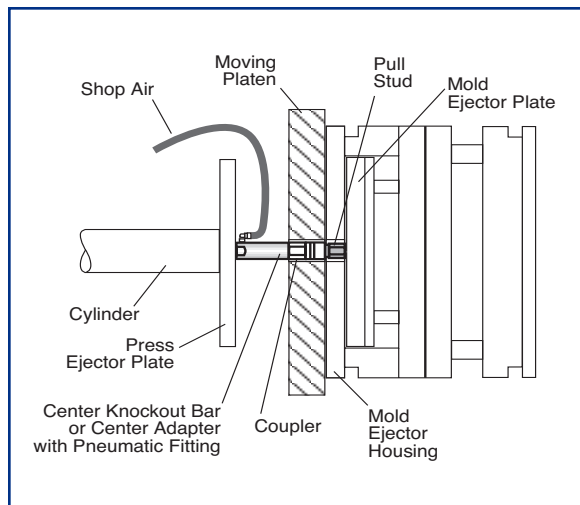

Center Bar and Coupler are installed into the Press Ejector Plate. Pull Stud is installed in the Mold Ejector Plate. Molds are changed quickly without accessing the back of the Press Ejector Plate.

Ejector housing shown is 1.062" thick.

Shop air is supplied to the side of the center adapter. No Air Manifold is needed. Fully-Threaded Center Bar may be shortened to proper length on-site.

Parts List	
Qty	Part
1	FasTie Pull Stud
1	FasTie Coupler
1	Center Bar or Center Adapter with Finished Bar

The largest possible FasTie Coupler and Pull Stud set is recommended for use in the center ejector position.

For small presses with a center knockout, replace the cylinder bolt (if present) with a Center Knockout Bar and FasTie Coupler.

Ask us about custom-machined ejector bar lengths or thread sizes to suit your application.

Captive Molder Application - Couplers at the End of Ejector Bars

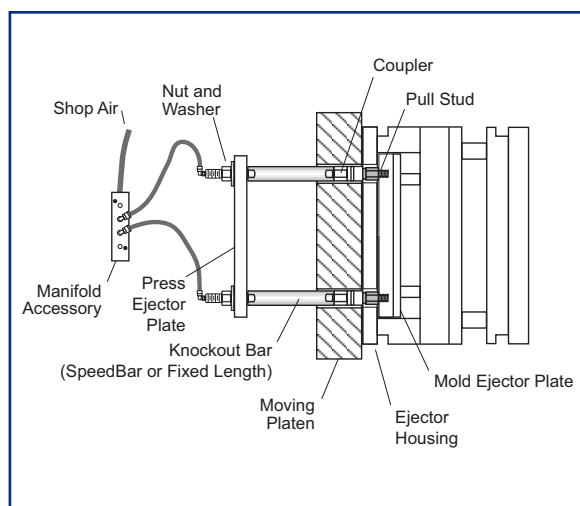

Couplers are located at the end of the knockout bars mounted to the press ejector plate.

Pull Studs are mounted to each mold in storage. Ejector connection is made without changing knockout bars.

Ejector housing shown is 1.062" thick.

Air Manifold supplies compressed air to the end of each knockout bar for simultaneous coupler release.

Smartflow Blank Bars (fixed length) are threaded one end only to be cut to length and threaded on site.

SpeedBar Adjustable Length Bars may be manipulated without tools +/- .5" from nominal in increments of .006".

Parts List	
Qty	Part
2 or 4	FasTie Pull Stud
2 or 4	FasTie Coupler
2 or 4	Blank Bar Fixed Length Knockout or SpeedBar® Adjustable Length Bar <i>Custom machining is available on request.</i>
1	Air Manifold with tubing

This setup is designed for captive molders, or shops with tools using a standard ejector stroke.

SMARTFLOW® *FasTie® Specifications*

Specifications

Maximum Operating Temperature	300°F (149°C)
Air Pressure Range	80 - 100psi
Pull Stud Material	Hardened Steel (58-62Rc)
Knockout Bar and Coupler Material.....	High Strength Steel
Threaded Studs	B7 Alloy or Comparable
Air Manifold Material.....	Aluminum
Air Tubing Material.....	1/8"OD Nylon

Press Requirements:

	Coupler Size			
	1-inch	1-3/8-inch	2-inch	3-inch
Platen thru hole min.	Ø1.063"	Ø1.45"	Ø2.063"	Ø3.063"
	Ø27mm	Ø36.8mm	Ø52.4mm	Ø77.8mm
Ejector Plate thru hole min.	Ø0.512"	Ø0.641"	Ø0.765"	Ø1.015"
	Ø14mm	Ø16.5mm	Ø19.4mm	Ø25.8mm
Ejector force per coupler max.	2.5 tons	5.5 tons	7.5 tons	15 tons

Recommended FasTie Size per Press Size & Knockout Qty

Press Tonnage	Knockout Quantity		
	1 (center)	2	4
0 - 250	1"HS	1"HS	1"HS
250 - 500	1-3/8"	1"HS or 1-3/8"	1"HS or 1-3/8"
500 - 750	2"	1-3/8" or 2"	1-3/8" or 2"
750 - 1000	2"	1-3/8" or 2"	1-3/8" or 2"
1000 +	-	2" or 3"	2" or 3"

For best results, use the largest FasTie that will fit into the press.

Accessories

Additional parts to aid installation and use:

- ◆ **Finished Bar Fixed Length Knockout** is a secure extension for FasTie Pull Stud attached to the mold ejector plate in a Typical Application (page 2). Finished Bars are ordered to your specified length and thread size for seamless installation.
- ◆ **Blank Bar Fixed Length Knockout** provides an air passage for FasTie Coupler operation at the back of the press ejector plate in Captive Applications (page 3). Several lengths are stocked with one blank end for on-site finishing (cut to length & thread).
- ◆ **SPEEDBAR Adjustable Length Knockout*** changes length without tools $\pm 1/2"$ in increments of .006". Air passes through the bar for air hook-up at the back of the press ejector plate in Captive Applications (page 3).
- ◆ **Center Adapter and Center Bar** provide an air passage in front of the press ejector plate for Center Knockouts (page 3) or Alternate Applications (page 2).
- ◆ **Air Manifold** splits single air supply into four circuits for simultaneous release of multiple FasTie Couplers. 1/8" diameter tubing and pneumatic connectors are included.

*1-inch, 1/2-13 threads only

1-Inch High Strength Couplers and Pull Studs

Do not use HS FasTie Couplers in combination with the original version. Damage to couplers will result. Maximum installed center line misalignment of coupler and pull stud is $\pm 3.5\text{mm}/0.138"$.

FTFHS-□□ FasTie High Strength Coupler	Model Number	Thread Size
	FTFHS-50	1/2-13
	FTFHS-63X	5/8-11(F)
	FTFHS-63	5/8-11
	FTFHS-M12	M12 x 1.75
	FTFHS-M16	M16 x 2
	FTFHS-M20	M20 x 2.5

FTFHS-□□ FasTie High Strength Pull Stud	Model Number	Thread Size
	FTMHS-38	3/8-16
	FTMHS-50	1/2-13
	FTMHS-63	5/8-11
	FTMHS-M12	M12 x 1.75
	FTMHS-M16	M16 x 2
	FTMHS-M20	M20 x 2.5

SMARTFLOW® FastTie® 1-Inch Accessories

Finished Bar Fixed Length Knockout (Typical Applications)

threaded both ends, cut to length

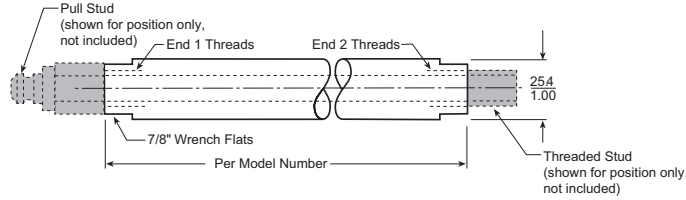

Model Number (Special Order X.XXX = Length in Inches)	End 1 Thread Size	End 2 Thread Size
FTFL-50-50-X.XXX	1/2-13	1/2-13
FTFL-50-63-X.XXX	1/2-13	5/8-11
FTFL-63-63-X.XXX	5/8-11	5/8-11
FTFL-M16-M16-X.XXX	M16 x 2	M16 x 2

Blank Bar Fixed Length Knockout (Alternate Applications)

1/2-13 threads one end only, finish on-site

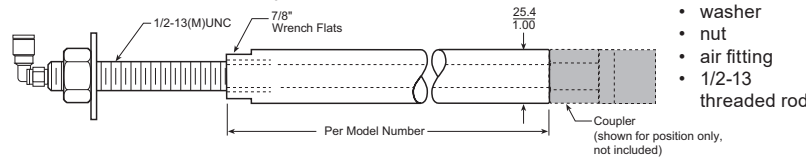

- Includes:
- washer
 - nut
 - air fitting
 - 1/2-13 threaded rod

Model Number	Length
FTBB-50-8	8"
FTBB-50-10	10"
FTBB-50-12	12"
FTBB-50-14	14"

*See page 8
to determine
knockout bar
length*

SpeedBar Adjustable Length Knockout

1/2-13 threads both ends, length per model number

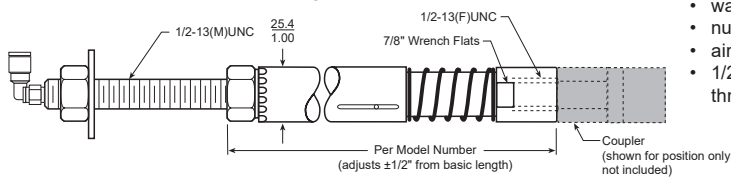

- Includes:
- washer
 - nut
 - air fitting
 - 1/2-13 threaded rod

Model Number	Length	Model Number	Length
SBAB-50-6	6"	SBAB-50-11	11"
SBAB-50-7	7"	SBAB-50-12	12"
SBAB-50-8	8"	SBAB-50-13	13"
SBAB-50-9	9"	SBAB-50-14	14"
SBAB-50-10	10"		

Center Adapter

(use with FTFHS-63X)

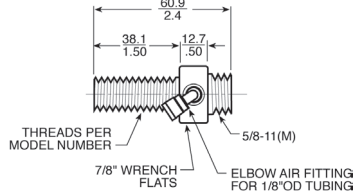

Model Number	Thread Size
FTCA-50	1/2-13
FTCA-63	5/8-11
FTCA-M12	M12 x 1.75
FTCA-M16	M16 x 2
FTCA-M20	M20 x 2.5



Center Adapter

Center Bar

(use with FTFHS-63 only)

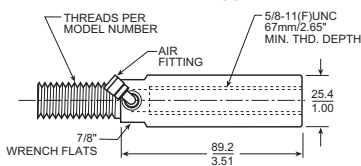

Model Number	Thread Size
FTCA-63-63	5/8-11
FTCA-M16-63	M16 x 2



Center Bar

Air Manifold (applies to all sizes)

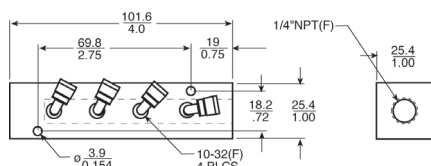

FTAM-100

- Includes:
- Manifold
 - (4) 1/8" elbow pneumatic fitting
 - (4) Ø1/8" x 4ft nylon tubing

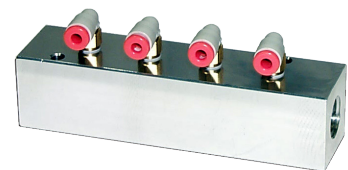

SMARTFLOW® FasTie® 1-3/8" Components

Maximum installed center line misalignment of coupler and pull stud is $\pm 5\text{mm}/0.197"$.

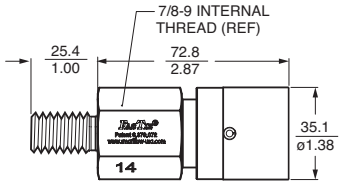
1-3/8" FasTie Coupler		Model Number	Thread Size	Model Number	Thread Size
		FTF1.4-50	1/2-13	FTF1.4-M16	M16 x 2
		FTF1.4-63	5/8-11	FTF1.4-M20	M20 x 2.5
		FTF1.4-75	3/4-10		
		FTF1.4-88X	7/8-9(F)		

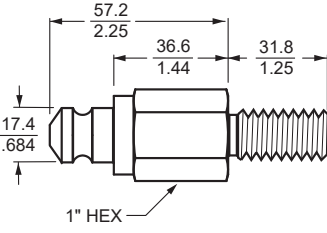
1-3/8" FasTie Pull Stud		Model Number	Thread Size
		FTM1.4-50	1/2-13
		FTM1.4-63	5/8-11
		FTM1.4-75	3/4-10
		FTM1.4-M16	M16 x 2
		FTM1.4-M20	M20 x 2.5

Contact your
Distributor
for Custom
Knockouts

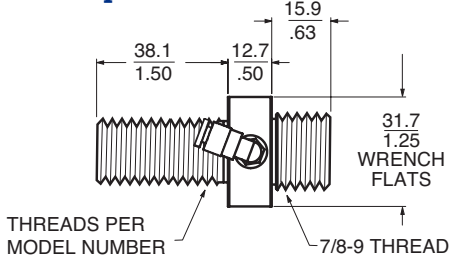
1-3/8" FasTie Center Adapter (use with FTF1.4-88X)		Model Number	Thread Size
		FTCA1.4-75	3/4-10
		FTCA1.4-M16	M16 x 2
		FTM1.4-M20	M20 x 2.5

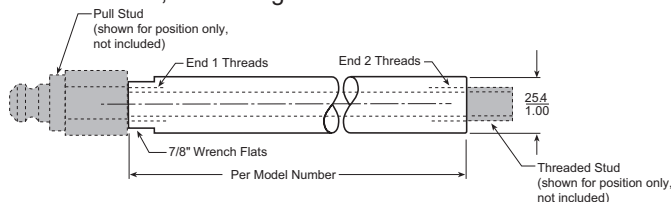
Finished Bar Fixed Length Knockout (Typical Applications) threaded both ends, cut to length	Model Number (Special Order X.XXX = Length in Inches)	End 1 Thread Size	End 2 Thread Size
	FTFL-50-50-X.XXX	1/2-13	1/2-13
	FTFL-50-63-X.XXX	1/2-13	5/8-11
	FTFL-63-63-X.XXX	5/8-11	5/8-11
	FTFL-M16-M16-X.XXX	M16 x 2	M16 x 2

SMED Friendly Smartflow Products

Manufacturing Engineers strive to reduce setup times and maximize machine run times, increasing profits.

A select group of **SMARTFLOW** products help manufacturing engineers achieve their goals:

FasTie® Quick Ejector Tie-In

Duoflow® Manifolds

SWAP® Valves

Duoflow Manifolds convert an internal operation to an external operation by connecting all cooling water lines permanently to a mold-mounted cooling water manifold. Reduce water hook-up to seconds by using one connection for Supply Water and one connection for Return Water with quick-disconnect fittings on the ends.



Sizes from 3/4" through 1-1/2" are available in standard and custom configurations. Port spacing is optimized to provide a compact manifold to save space. Molds in storage are ready to hang.

SMARTFLOW® *FasTie*® 2" Components

Maximum installed center line misalignment of coupler and pull stud is $\pm 6\text{mm}/0.236''$.

2" FasTie Coupler	Model Number		Thread Size	
		FTF2-63	5/8-11	FTF2-M16
FTF2-75		3/4-10	FTF2-M20	M20 x 2.5
FTF2-113X		1-1/8-12(F)		

2" FasTie Pull Stud	Model Number		Thread Size	
		FTM2-63	5/8-11	
FTM2-75		3/4-10		
FTM2-M16		M16 x 2		
FTM2-M20		M20 x 2.5		

*Contact your
Distributor
for Custom
Knockouts*

2" FasTie Center Adapter (use with FTF2-113X)	Model Number		Thread Size	
		FTCA2-75	3/4-10	
FTCA2-M16		M16 x 2		
FTM2-M20		M20 x 2.5		

Finished Bar Fixed Length Knockout (Typical Applications) threaded both ends, cut to length	Model Number		End 1	End 2
	(Special Order X.XXX = Length in Inches)		Thread Size	Thread Size
	FTFL2-63-63-X.XXX	5/8-11	5/8-11	5/8-11
	FTFL2-63-75-X.XXX	5/8-11	3/4-10	3/4-10
	FTFL2-75-75-X.XXX	3/4-10	3/4-10	3/4-10
	FTFL2-M16-M16-X.XXX	M16 x 2	M16 x 2	M16 x 2
	FTFL2-M16-M20-X.XXX	M16 x 2	M20 x 2.5	M20 x 2.5
	FTFL2-M20-M20-X.XXX	M20 x 2.5	M20 x 2.5	M20 x 2.5

SMED Friendly SWAP® Valves reduce time required for cooling line evacuation between mold changes to seconds instead of minutes while keeping shop floors clean. SWAP Valves use shop air to evacuate fluid from cooling lines with a single handle motion. The mold can then be changed. Resume main cooling fluid supply with the reverse handle motion.

An optional locking pin prevents accidental valve position change for added process security.



SMARTFLOW® FasTie® 3" Couplers and Pull Studs

Maximum installed center line misalignment of coupler and pull stud is $\pm 5\text{mm}/0.197''$.

3" FasTie Coupler

Model Number	Thread Size
FTF3-M42	M42 x 3
FTF3-M42X	M42 x 3(F)

Call for quotation on thread sizes not shown (1" minimum)

3" FasTie Pull Stud

Model Number	Thread Size
FTM3-M36	M36 x 4
FTM3-M36X	M36 x 4(F)

Determine Knockout Bar Length

- ◆ Determine length of Solid Knockout Bar
- ◆ Select Connected FasTie Length from table
- ◆ Subtract Connected FasTie Length from Solid Knockout Bar Length
- ◆ Subtract Center Adapter Length if needed
- ◆ Result is FasTie Knockout Bar Length

Note: When using two or more knockout bars in an installation, knockout bars must be the same length within .05mm (.002") to assure even coupler operation.

Connected FasTie Lengths		
Description	Part Numbers	"X" Length
High Strength 1" FasTie	FTFHS-xx and FTMHS-xx	80.3mm/3.162"
1-3/8" FasTie	FTF2.4-xx and FTM1.4-xx	109.2mm/4.300"
2" FasTie	FTF2-xx and FTM2-xx	149.2mm/5.875"
3" FasTie	FTF3-xx and FTM3-xx	209.6mm/8.250"

Typical Application, Bar Length

Alternate Application, Bar Length

Maximum Installed Misalignment (ref.)

Maximum center line misalignment per coupler size:

1"HS	$\pm 3.5\text{mm}$	$(\pm 0.138'')$
1-3/8"	$\pm 5\text{mm}$	$(\pm 0.197'')$
2"	$\pm 6\text{mm}$	$(\pm 0.236'')$
3"	$\pm 5\text{mm}$	$(\pm 0.197'')$

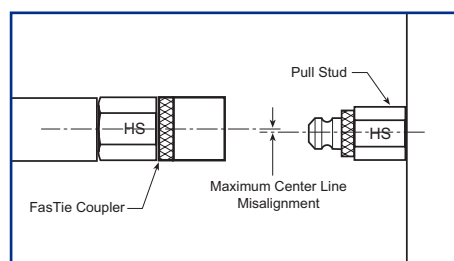

Minimum Clearance Needed to Disengage Coupler and Pull Stud

1"HS	15mm	(0.59")
1-3/8"	21mm	(0.81")
2"	25mm	(1.00")
3"	34mm	(1.34")