

COUNTERVIEW® 100/200 SERIES



Progressive's CounterView positively monitors mold activity, validates process monitoring data, and assists mold maintenance procedures.

- Maximum operating temperature is 250° F (120° C)
- Counter: Non-resettable mechanical, 7-digit

M Glass-filled Nylon housing

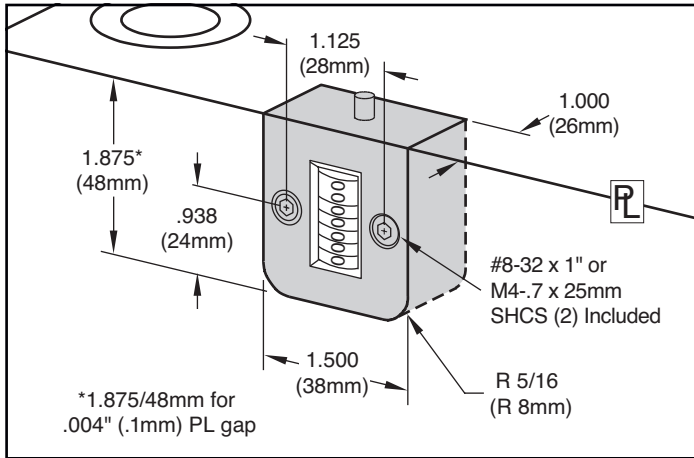

PARTING LINE MOUNT	Parting line mount makes unit easily visible to operator.
CVPL-100	Inch Standard
CVPL-200	Metric Standard

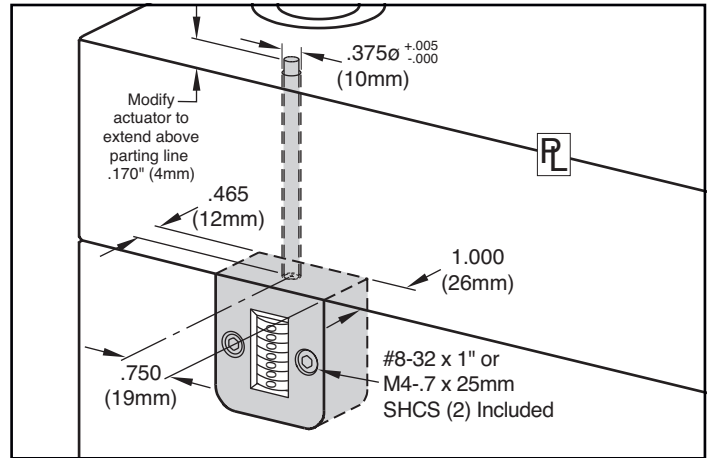

INTERNAL EXTENSION MOUNT	Machinable 8" (200mm) extension allows installation in sup. plate or rail.
CVIN-100	Inch Standard
CVIN-200	Metric Standard

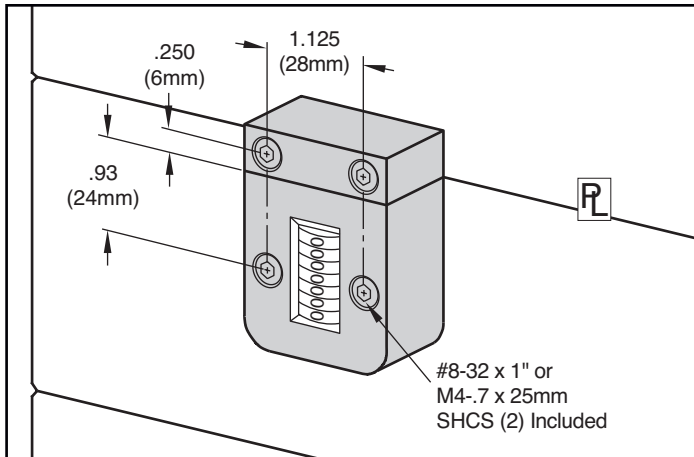

EXTERNAL MOUNT	No pocket machining necessary. Designed specifically for retrofit applications.
CVEX-100	Inch Standard
CVEX-200	Metric Standard



ID Plates for tool identification sold separately. Contact Customer Service for special ID Plates with your company's logo.

CATALOG NUMBER	DESCRIPTION
CVID	ID Plate for tool identification