



CounterView®

100/200 Series



M Glass-filled Nylon housing

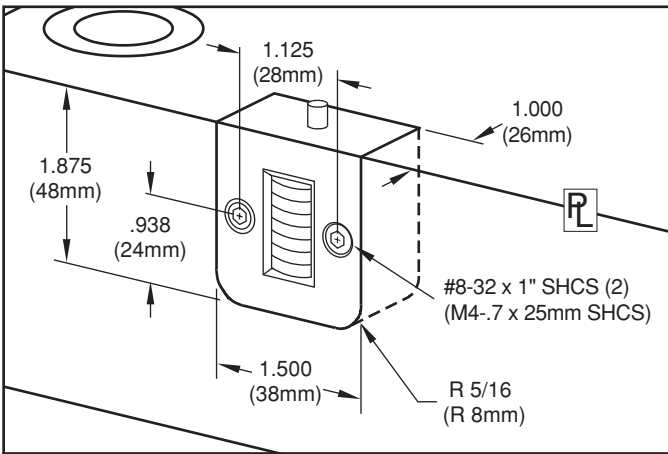

Parting Line Mount		Parting line mount makes unit easily visible to operator.	
CVPL-100	Inch Standard		
CVPL-200	Metric Standard		

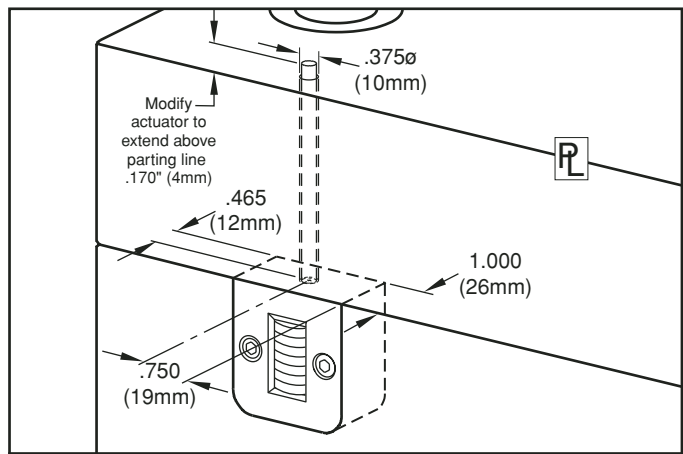

Internal Extension Mount		Machinable 8" extension allows installation in sup.plate or rail.	
CVIN-100	Inch Standard		
CVIN-200	Metric Standard		

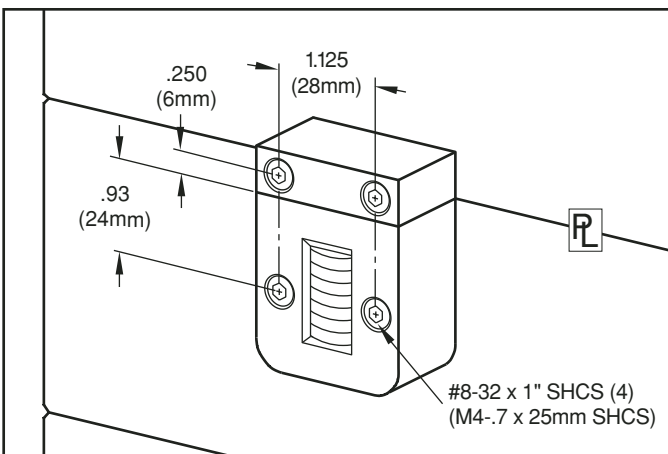

External Mount		No pocket machining necessary; Designed specifically for retrofit applications.	
CVEX-100	Inch Standard		
CVEX-200	Metric Standard		

Specifications:

- Maximum operating temperature is 250°F (120°C)
- Counter: Non-resettable mechanical, 7-digit
- Screws included.
- Includes a serial number for tracking via www.profileCV.com.

ID Plates for tool identification sold separately.

Catalog Number	Description
CVID	ID Plate for tool identification

Contact Customer Service for special ID Plates with your company's logo.

D www.procomps.com/design